

YLCASTER CATALOG

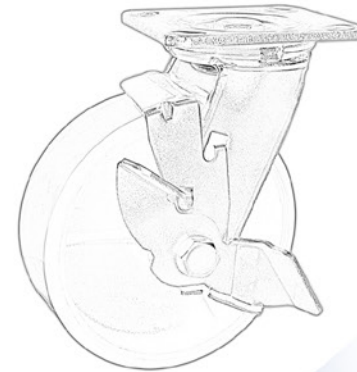

Manufacturing master of caster

GUANGZHOU YLCASTER METAL CO.,LTD.

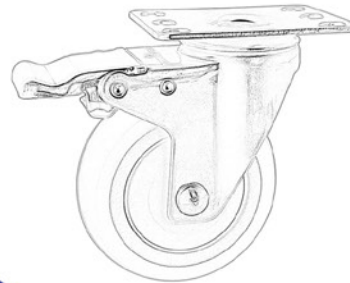
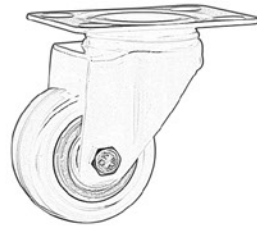
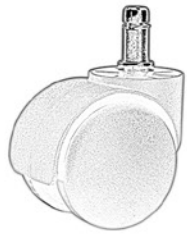

ISO9001-2015



About Us 公司简介



Established in 1997 and located in Yangjiang city in China, Guangzhou YLcaster Metal Co., Ltd. is one of the most famous caster wheel and hand trolley manufacturers, suppliers and exporters, covering an area of 35,000 square meters with more than 20 experts and about 150 workers. In 2018, we have the honor of becoming one of the top 10 caster brandings in China.

As a professional caster wheel manufacturer for more than 20 years, Our factory specializes in caster wheel research, design, manufacture and exportation. Our R&D team will work with you for your special requirements of every products.

We supply our products worldwide. With the production capacity of more than 1 million pieces per month, the annual amount of our factory has reached to USD 30 millions. Our reliable quality and sincere service are highly recognized by our customers all over the world.

Our brand Weibida own the certificate of RoHS and our factory pass the ISO 9001:2015. All our products are tested strictly based on EN12531 and salt-spray standard.

In order to meet the market demands, we always keep paying attention to improving and developing our products and ourselves. Currently we offer more than 2000 different kinds of high quality casters combinations for every applications such as: industrial machinery, medical facilities, furniture, hand trolley, shopping carts, hand pallets, scaffolding, shelves and so on.

The only thing we dedicate to is to satisfy your needs with our high quality products, timely services and competitive prices. If you are interested in our products, please feel free to contact us for more details.

广州粤轮金属有限公司成立于 1997 年，中国优质脚轮及手推车知名专业制造厂商及出口商之一。2018 年，我们荣幸地成为中国十大脚轮品牌之一。工厂位于广东省阳江市，占地面积 35,000 平方米，拥有超过 170 人的设计生产团队。20 多年的脚轮研制开发、生产和经营经验，我们非常有信心满足不同的客户需求。我们的产品销往世界各地，客户遍布全球。工厂的月生产能力超过一百万件，年产值达到三千万美元。我们扎实的产品质量和真诚服务赢得了客户的一致好评。我们的自有品牌威必达，拥有证书 RoHS。工厂获得了 ISO 9001:2015 质量体系认证。脚轮均通过 EN12531 标准的行走、载重以及严格的盐雾测试。为了满足市场需求，我们一直致力于提升自我，改进和研发新的产品。目前，我们有超过 2000 个不同的高品质脚轮组合，能适配各个领域的应用。例如：工业机械、医疗设备、家具、手推车、购物车、叉车、脚手架、货架等。为您提供有竞争力的价格、优质的产品和服务，是我们粤轮人唯一的追求。如果您对我们的产品感兴趣，请随时联系我们了解更多详情。

Certificates 证书



Our Factory 工厂风采





EN12531 动态脚轮测试标准 EN12531 Dynamic Load Test Standard

Test items 测试项目	Test standard 测试标准
Speed 轮子测试速度	1.1meter/second(4kilometer/hour) 1.1 米 / 秒 (4 公里 / 小时)
Barrier height 障碍物高度	2.5% of wheel dia. (wheel rigidity \geq 90 degrees SHORE A) 轮子直径的 2.5% (轮胎硬度 \geq 90 度 SHORE A)
	5% of wheel dia. (wheel rigidity \leq 90 degrees SHORE A) 轮子直径的 5% (轮胎硬度 \leq 90 度 SHORE A)
Space between barrier 障碍物间隔	1-3meter 1-3 米
Hitting barrier 碰撞障碍物次数	500times 500 次
Stop period 停顿时间	After three mins running , stop a min 每走 3 分钟停一分钟
Running times 轮子转动次数	15000 (Wheel girth x 15000 times=total length) 15000 (轮子周长 X15000 次 = 全程长度)

Production Process
生产流程

Icon Information 图标信息



Wheel diameter
轮径



Bore diameter
轴径

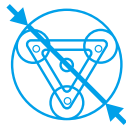

Diameter
轮径

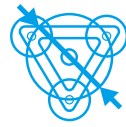

Hole diameter
轴径

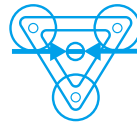

Bolt hole diameter
孔径

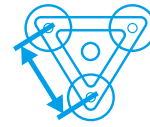

Bolt hole spacing
孔距



Load capacity
载荷



Single wheel
单轮



Bearing
轴承



Ball bearing
滚珠轴承



Roller bearing
滚针轴承



Plain bearing
滑动轴承

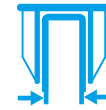

Fork width
支架开口宽



Tread width
轮宽



Hub width
轴宽



Overall height
安装高度

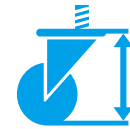

Threaded stem type overall height
丝杆安装高度

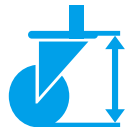

Grip stem type overall height
卡簧安装高度

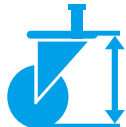

Stem type overall height
插杆安装高度

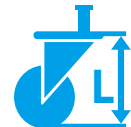

Long stem type overall height
长插杆安装高度



Grip stem size
卡簧尺寸



Threaded stem size
丝杆尺寸



Stem size
插杆尺寸



Long stem size
长插杆尺寸

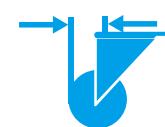

Turning radius
旋转半径

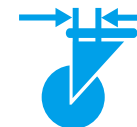

Offset
偏心距



Hole diameter
孔径



Inner diameter
内径

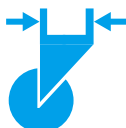

Clamp wide
夹板宽

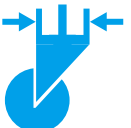

Tube diameter
管径

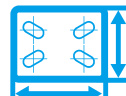

Top-Plate size
底板尺寸

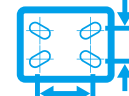

Bolt hole spacing
孔距



Bolt hole diameter
孔径



Fixed type top-plate size
固定底板尺寸



Fixed type bolt hole spacing
固定孔距



Fixed type bolt hole diameter
固定孔径



Trolley Overall height
板车安装高度

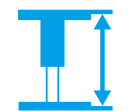

Compression height
压缩高度

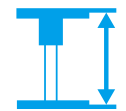

Stretching height
伸展高度

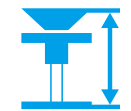

Load height
载荷高度



Hand trolley size
板车尺寸



Hand trolley height
板车高度

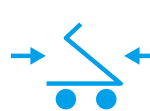

Folding size
折叠尺寸



Hand trolley weight
板车重量



Hand trolley load capacity
板车载荷



Ladder load capacity
爬梯车载荷

HOW TO CHOOSE CASTERS

Using casters can reduce the work force and increase the work efficiency. The right caster should be chosen by the manner of application, condition and request (for example facility, labor-saving, durability). The factor must be considered as follows:

■ The load capacity

(1) Load:

$$T = \frac{E + Z}{M}$$

T = each caster load

E = the weight of the vehicle

Z = the weight of moving object

M = efficient load casters quantity

(the position and different heavy distribution must be considered)

(2) Efficient load caster quantity as follows :

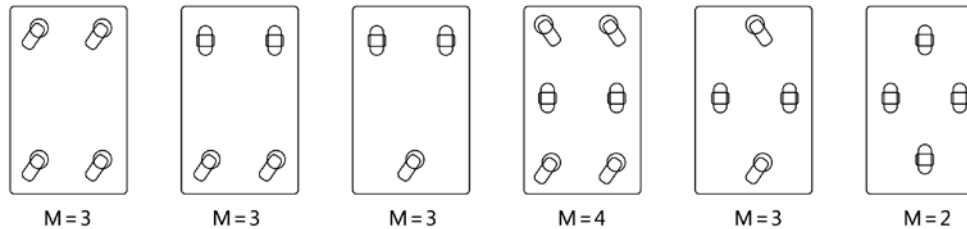

(3) The casters load at the position of maximum should be considered when choose load capacity. Concrete load position and maximum position (P2) as follows:

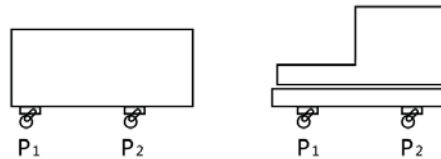

■ Agility

(1) The part of turn (frame turn, wheel rolling) should choose the mini friction material, or the accessories which be made by a special technology, such as pin ball bearing or quenched in order that the casters will be used easy and durable.

(2) The bigger the eccentricity is, the better the agility becomes. But the load capacity is reduced accordingly.

(3) The bigger the wheel diameter is, the more labor-saving it becomes, and can protect the floor surface perfectly. The bigger wheels run much slowly, not easily getting heated and distorted, and more durable than the small. It is better to choose the bigger diameter wheel when the fitting height is enough.

如何选择脚轮

使用脚轮是为了减轻劳动强度,提高工作效率。根据应用的方式、条件和要求(方便、省力、耐用)正确地选择适合你使用的脚轮。请考虑以下几点:

■ 承载重量:

$$T = \frac{E + Z}{M}$$

(1) 承载重量计算

T = 每只脚轮承载的重量

E = 运输工具的重量

Z = 移动物体的重量

M = 轮子有效承载数量

(应考虑位置,重量分布不均的因素)

(2) 轮子有效承载数量 (M) 如下图:

(3) 选择承重时要按量大支撑点处脚轮的承重量计算。脚轮具体受力支撑点如下图, P2 为最重支撑点。

■ 灵活性

(1) 脚轮应灵活、轻松并耐用,其转动部位(脚架转动,轮子滚动)应选用摩擦系数小的材料或经特殊工艺处理后组装的配件(如滚珠轴承或淬火处理。)

(2) 脚架的偏心距越大转向越灵活,但承载能力相应降低。

(3) 轮子的直径越大推动越省力,并能更好地保护地面。轮子大比小转动缓慢,不易发热变形,更耐用。在安装高度允许的条件下尽可能选择大直径的轮子。

■ Moving speed

The request of caster speed : at the normal temperature and on the smooth floor, the speed should be lower than 4km/h of walk and there is static interval during the work time.

■ Applied environment

The floor material, barrier, leftover and the special environment, such as scrap iron, high or low temperature, great acidity and alkalescence, oil liquor, chemistry solvent and anti-static-electricity, should be considered when choose the caster.

Caster used in special environment should be made of special materials.

■ Fitting notice:

Plate : fitted plate must be level, hard and firm.

Rigid : the direction of two wheels must be accordant and paralle.

Thread : must be fitted with spring shim to prevent from loosening.

■ 移动速度

脚轮速度的要求在常温环境下，在平坦的地面上不高于步行速度 4KM/H, 并有一定停歇的工作状态。

■ 使用环境

选择时应考虑地面材料、障碍物、残留物或特殊环境（如铁屑、高温、低温、酸性大、碱性大、油液和化学溶剂以及要求抗静电的场所）。在特殊环境中使用的应选择用特殊材料制成的脚轮。

■ 安装注意事项

平顶：安装面必须平整、硬质、不许松动。

定向：两轮子必须方向一致，并且保证

平行：丝口必须配弹簧垫片，防止松动。

轮子材料的性能特点 Wheel Material Capability & Characteristic

材料名称 Type	承载范围 Load (kg)	灵活性 Agility	地板保护 Floor Protection	转动安静 Silence	抗震 Shockresistance	耐磨损 Abrasion- resistance	耐化学性能 Chemistry-resistance	适用温度°C Suitable Temperature	轮子硬度 (A) Hardness	说明 Description
聚烯烃 FP	10-500	优 Best	差 Bad	差 Bad	差 Bad	差 Bad	优 Best	-20~80	-	纯轮 Pure wheel
尼龙 PA	20-1000	优 Best	差 Bad	差 Bad	差 Bad	良 Better	优 Best	-35~100	-	纯轮 Pure wheel
高强度尼龙 TPA	50-2000	优 Best	差 Bad	差 Bad	差 Bad	优 Best	优 Best	-35~120	-	纯轮 Pure wheel
橡胶 (高弹性) Rubber (high elastic)	20-600	一般 Common	优 Best	优 Best	优 Best	良 Better	一般 Common	-42~80	68±3	内芯铝合金、尼龙 Al.alloy/PA core
人造胶 Synthetic Plastic	20-300	一般 Common	优 Best	优 Best	良 Better	一般 Common	良 Better	-30~80	90±3	内芯工程塑料 Plastic core
超级人造胶 TPE	20-600	一般 Common	优 Best	优 Best	优 Best	良 Better	一般 Common	-40~85	75±3	内芯工程塑料 Plastic core
耐磨塑胶 Plastic	20-800	一般 Common	优 Best	优 Best	良 Better	良 Better	优 Best	-30~85	95±3	内芯工程塑料 Plastic core
聚氨酯 PU	30-1000	良 Better	优 Best	优 Best	优 Best	优 Best	优 Best	-40~90	95±3	内芯工程塑料 Plastic core
高强度聚氨酯 TPU	50-3000	良 Better	优 Best	优 Best	优 Best	优 Best	优 Best	-40~90	95±3	内芯铝合金、尼龙、铸铁 Al.alloy/PA/Moulded steel core
铸铁 Cast Iron	50-5000	优 Best	差 Bad	差 Bad	差 Bad	优 Best	一般 Common	-50~600	-	铸铁、锻钢、合金 或其他金属 Cast Iron/Forged steel/Alloy/Other metal core

Model Description

型号说明

I001		A		065		PVC		P		B	
Series		Type		Wheel Diameter		Wheel Material		Fastening Type		Brake Type	
F001	Plastic Caster 塑料轮	A	Type A A款	025	1"	APU	Aluminium Core Polyurethane 铝芯聚氨酯	D	Bolt Hole 孔顶	B	Double Brake 双刹车
F002	Ball Caster 球轮			030	1.2"	AR	Aluminium Core Rubber 铝芯橡胶	G	Grip Ring Stem 卡簧	B1	Side Brake 侧刹车
F001	Office Chair Caster-1 班椅轮 -1			032	1.2"	C	Cast Iron 铸铁	P	Plate Style 底板款	B2	Nylon Pedal Double Brake 尼龙踏板双刹车
F004	Office Chair Caster-2 班椅轮 -2			038	1.5"	CPU	Cast Iron Core Polyurethane 铁芯聚氨酯	F	Fixed 固定	B3	Back Brake 后刹车
F005	Brown TPR Caster 棕色 TPR 脚轮			040	1.5"	CR	Cast Iron Core Rubber 铁芯橡胶	S	Stem 插杆	B4	Position Lock 方向锁
F006	Transparent Caster 透明脚轮			050	2"	ER	Elastic Rubber 弹力橡胶	SL	Long Stem 长插杆	B5	Front Brake 前刹车
F007	Soft Transparent PU Caster 花芯透明脚轮			060	2.5"	FP	Polymer 共聚	T	Threaded Stem 丝杆	B6	Nylon Front Brake 尼龙踏板前刹车
				065	2.5"	HR	Hard Rubber 硬橡胶				
M001	Medical Caster-1 医疗脚轮 -1			075	3"	PA	Nylon 尼龙				
M002	Medical Caster-2 医疗脚轮 -2			080	3"	PF	Phenolic 酚醛				
M003	Medical Caster-3 医疗脚轮 -3			085	3.5"	PP	Plastic 塑料				
M004	Medical Caster-4 医疗脚轮 -4			100	4"	PU	Plastic Core Polyurethane 塑芯聚氨酯				
M005	Medical Caster-5 医疗脚轮 -5			125	5"	PVC	Polyvinyl Chloride 聚氯乙烯				
M006	Medical Caster-6 医疗脚轮 -6			150	6"	TPR	Thermoplastic Rubber 热塑性橡胶				
				160	6"	SS	Stainless Steel 不锈钢				
T001	Platform Foldable Trolley 折叠平板车			180	7"	BS	Black Steel 黑色钢				
T002	Multi-layer Plastic Trolley 多层塑料推车			200	8"	ST	Square Tube 方管				
T003	Wire Mesh Trolley 网笼车			250	10"						
T004	Foldable Transport Truck 折叠行李车			300	12"						
T005	Foldable Stair-Climbing Trolley 爬梯车			350	14"						
				400	16"						

目录 Contents

Industrial Series





	I001 Light Duty Caster 轻型脚轮	1
	I002 Medium Duty Caster 中型脚轮	15
	I003 Medium Heavy Duty Caster 中重型脚轮	25
	I004 Heavy Duty Caster 重型脚轮	29
	I005 Super Heavy Duty Caster 超重型脚轮	47
	I006 Standard Industrial Caster 标准工业脚轮	51
	I007 European Type Caster 欧款脚轮	55
	I008 Stainless Steel Caster 不锈钢脚轮	67
	I009 Low Profile Caster 低重心脚轮	73
	I010 Scaffolding Caster 脚手架脚轮	77

	I011 Shock Absorbing Caster 减震脚轮	83
	I012 Floor Lock 顶高器	85
	I013 Shopping Cart Caster 购物车脚轮	86
	I014 Waste Bin Caster 垃圾桶脚轮	87
	I015 Stair Climbing Wheel 爬梯轮	88
	I016 Leveling Caster 水平调节轮	88
	I017 Workbench Caster 工作台脚轮	90
	I018 Hand Pallet Wheel 叉车轮	91
	I019 Groove Caster 槽轮	93
	I020 Heat Resistant Caster 耐高温脚轮	95
	I021 Conductive Caster 导电脚轮	97
	I022 Anti-Static Caster 防静电脚轮	99
	I023 Food Cart Caster 餐车脚轮	101







Furniture Series

	F001 Plastic Caster 塑料轮	103
	F002 Ball Caster 球轮	104
	F003 Office Chair Caster-1 班椅轮 -1	105
	F004 Office Chair Caster-2 班椅轮 -2	106
	F005 Brown TPR Caster 棕色 TPR 脚轮	107
	F006 Transparent PU Caster 透明脚轮	111
	F007 Soft Transparent PU Caster 花芯透明脚轮	112

Trolley Series

	T001 Foldable Plastic Platform Trolley 折叠平板推车	121
	T002 Multi-layers Plastic Platform Trolley 多层塑料推车	123
	T003 Wire Mesh Trolley 网笼车	123
	T004 Foldable Transport Truck 折叠行李车	124
	T005 Foldable Stair-Climbing Trolley 爬梯车	124

Medical Series

	M001 Medical Caster-1 医疗脚轮 -1	113
	M002 Medical Caster-2 医疗脚轮 -2	114
	M003 Medical Caster-3 医疗脚轮 -3	115
	M004 Medical Caster-4 医疗脚轮 -4	117
	M005 Medical Caster-5 医疗脚轮 -5	119
	M006 Medical Caster-6 医疗脚轮 -6	120

I001



I001 Series Light Duty Caster Wheel Types Preview

I001 轻型脚轮系列款式预览

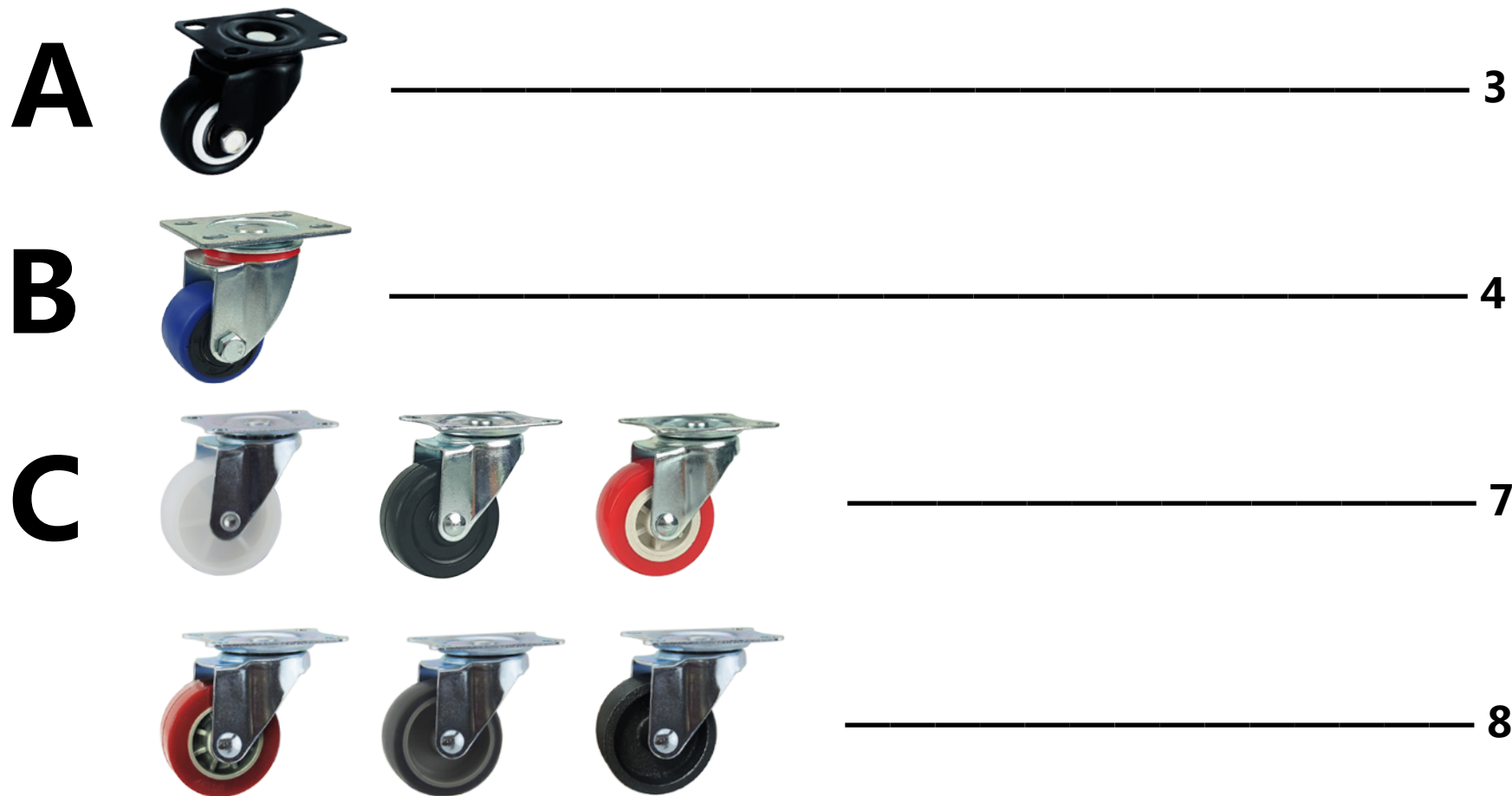

YI-GAS-STER

Light Duty Caster 轻型轮

I001



YI-GAS-STER

D



_____ 10

E



_____ 11

G



_____ 13

Light Duty Caster Type A A 款轻型脚轮

I001



Housing:

Made of pressed steel, electrophoresis finished, double ballrace swivel head

Wheel:

Material: PVC/PP/TPR

Bearing type: Double ball bearing

支架:

冲压电泳铁支架, 双玻盘

轮子:

材料: 聚氯乙烯 / 塑料 / 热塑性橡胶

轴承类型: 双滚珠轴承



Model Number									
I001A040PVC	40x20	60	60x43	45x30	9x6	/	10x25		30
I001A050PVC	50x24	71	70x50	50x35	11x8	10.5	10x25		40
I001A065PVC	63x32	90	93x62	72x45	12x8.5	12.5	12x30		60
I001A075PVC	75x32	107	93x62	72x45	12x8.5	12.5	12x30		70

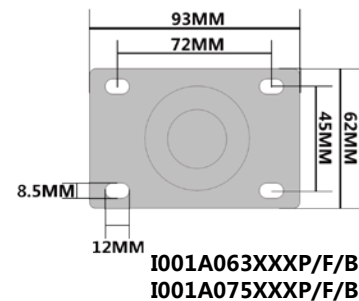
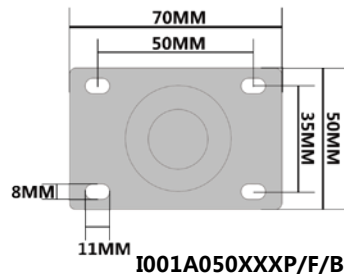
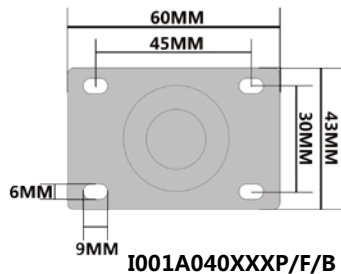

Optional wheels 匹配脚轮:



YI-CAS-TER

Light Duty Caster Type B B 款轻型脚轮

I001

Housing:

Made of pressed steel, zinc plated ,
double ballrace swivel head

Wheel:

Material: Polymer/TPR

Bearing type: Precision double ball bearing

支架:

冲压镀锌铁支架, 双球盘

轮子:

材料: 共聚 / 热塑性橡胶

轴承类型: 精密双滚珠轴承



I001B050XXXP



I001B050XXPF



I001B050XXXPB



I001B050XXXT



I001B050XXXTB

Model Number									
I001B050FPP	50x32	80	80x60	58x35	12x8	12.5	12x30		110
I001B050TPRP	50x32	80	80x60	58x35	12x8	12.5	12x30		70

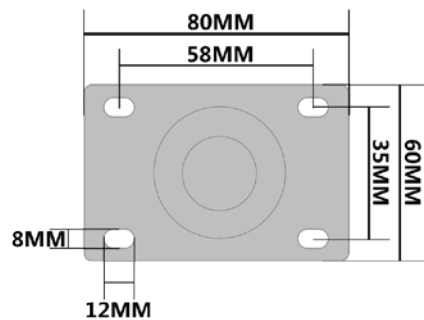

I001B050XXXP/F/B

Optional wheels 匹配脚轮:



Y-L-CAS-STER

Light Duty Caster Type C C 款轻型脚轮

I001



Housing:

Made of pressed steel, zinc plated, single ballrace swivel head

Wheel:

Material: PP/Rubber/PVC/PU/TPR/Cast Iron

支架:

冲压镀锌铁支架, 单玻盘

轮子:

材料: 塑料 / 橡胶 / 聚氯乙烯 / 聚氨酯 / 热塑性橡胶 / 铸铁



I001CXXXRP



I001CXXXRPF



I001CXXXRPB1



I001CXXXRD



I001CXXXRDB1



I001CXXXRT



I001CXXXRTB1

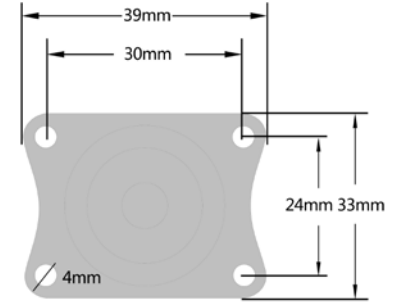

I001C025XXXP/B1

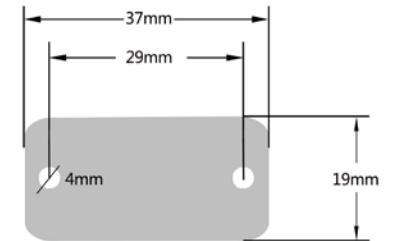

I001C025XXXPF

Y1-CAS-STER

Light Duty Caster Type C

C 款轻型脚轮

I001



YI-GAS-STER

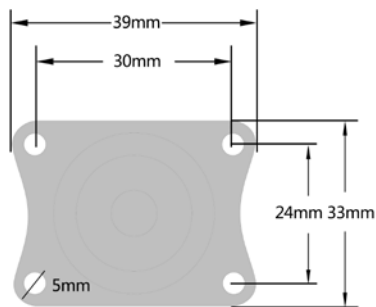

I001C030XXX/B1

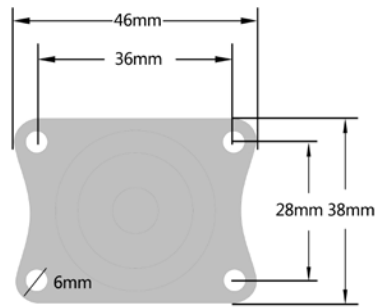

I001C040XXX/B1

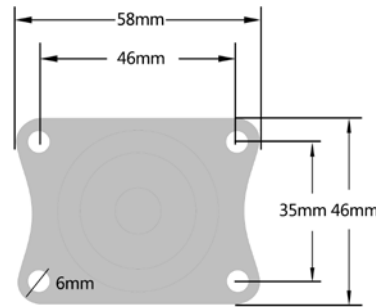

I001C050XXX/B1

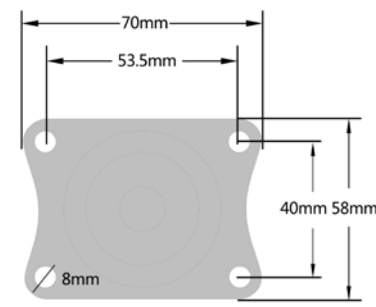

I001C065XXX/B1
I001C075XXX/B1

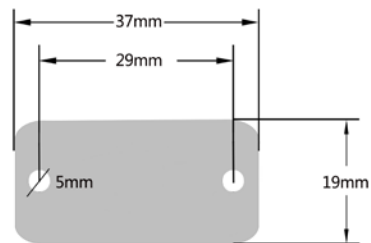

I001C030XXX/PF

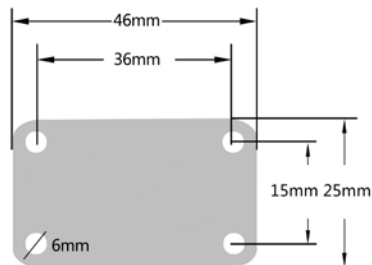

I001C040XXX/PF

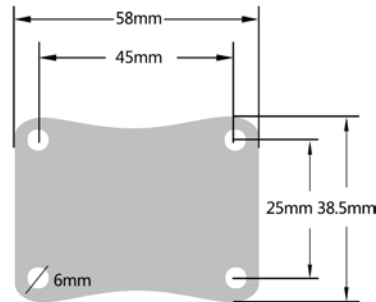

I001C050XXX/PF

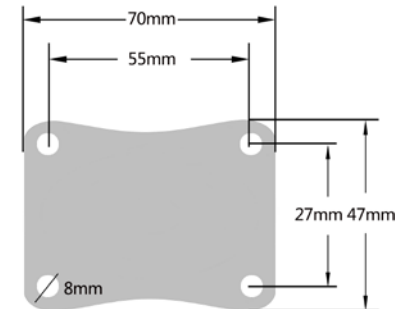

I001C065XXX/PF
I001C075XXX/PF

Light Duty Caster Type C C 款轻型脚轮

I001



Y1-CAS-TER



Wheel Material	Model Number											
PP 塑料	I001C025PPP	25x13	38	39x33	30x24	37x19	29	4	/	/	/	10
	I001C030PPP	30x13	40	39x33	30x24	37x19	29	5	/	/	/	15
	I001C040PPP	40x16.3	50.5	46x38	36x28	46x25	36x15	6	/	8x15	/	20
	I001C050PPP	50x20.3	65	58x46	46x35	58x38.5	45x25	6	8.5	8x15	/	30
	I001C065PPP	65x25	84	70x58	53.5x40	70x47	55x27	8	10.5	10x25	/	40
	I001C075PPP	75x25	93	70x58	53.5x40	70x47	55x27	8	10.5	10x25	/	50
Rubber 橡胶	I001C025RP	25x13	38	39x33	30x24	37x19	29	4	/	/	/	10
	I001C030RP	30x13	40	39x33	30x24	37x19	29	5	/	/	/	15
	I001C040RP	40x16.3	50.5	46x38	36x28	46x25	36x15	6	/	8x15	/	20
	I001C050RP	50x20.3	65	58x46	46x35	58x38.5	45x25	6	8.5	8x15	/	30
	I001C065RP	65x25	84	70x58	53.5x40	70x47	55x27	8	10.5	10x25	/	40
	I001C075RP	75x25	93	70x58	53.5x40	70x47	55x27	8	10.5	10x25	/	50
PVC + PP Core 塑芯 聚氯乙烯	I001C025PVCP	25x13	38	39x33	30x24	37x19	29	4	/	/	/	10
	I001C030PVCP	30x13	40	39x33	30x24	37x19	29	5	/	/	/	15
	I001C040PVCP	40x16.3	50.5	46x38	36x28	46x25	36x15	6	/	8x15	/	20
	I001C050PVCP	50x20.3	65	58x46	46x35	58x38.5	45x25	6	8.5	8x15	/	30
	I001C065PVCP	65x25	84	70x58	53.5x40	70x47	55x27	8	10.5	10x25	/	40
	I001C075PVCP	75x25	93	70x58	53.5x40	70x47	55x27	8	10.5	10x25	/	50

Light Duty Caster Type C C 款轻型脚轮

I001



Wheel Material	Model Number											
PU + PP Core 塑芯聚氨酯	I001C025PUP	25x13	38	39x33	30x24	37x19	29	4	/	/	/	10
	I001C030PUP	30x13	40	39x33	30x24	37x19	29	5	/	/	/	15
	I001C040PUP	40x16.3	50.5	46x38	36x28	46x25	36x15	6	/	8x15	/	20
	I001C050PUP	50x20.3	65	58x46	46x35	58x38.5	45x25	6	8.5	8x15	/	30
	I001C065PUP	65x25	84	70x58	53.5x40	70x47	55x27	8	10.5	10x25	/	40
	I001C075PUP	75x25	93	70x58	53.5x40	70x47	55x27	8	10.5	10x25	/	50
TPR + PP Core 塑芯热塑橡胶	I001C025TPRP	25x13	38	39x33	30x24	37x19	29	4	/	/	/	10
	I001C030TPRP	30x13	40	39x33	30x24	37x19	29	5	/	/	/	15
	I001C040TPRP	40x16.3	50.5	46x38	36x28	46x25	36x15	6	/	8x15	/	20
	I001C050TPRP	50x20.3	65	58x46	46x35	58x38.5	45x25	6	8.5	8x15	/	30
	I001C065TPRP	65x25	84	70x58	53.5x40	70x47	55x27	8	10.5	10x25	/	40
	I001C075TPRP	75x25	93	70x58	53.5x40	70x47	55x27	8	10.5	10x25	/	50
Cast Iron 铸铁	I001C025CP	25x13	38	39x33	30x24	37x19	29	4	/	/	/	10
	I001C030CP	30x13	40	39x33	30x24	37x19	29	5	/	/	/	15
	I001C040CP	40x16.3	50.5	46x38	36x28	46x25	36x15	6	/	8x15	/	20
	I001C050CP	50x20.3	65	58x46	46x35	58x38.5	45x25	6	8.5	8x15	/	30
	I001C065CP	65x25	84	70x58	53.5x40	70x47	55x27	8	10.5	10x25	/	40
	I001C075CP	75x25	93	70x58	53.5x40	70x47	55x27	8	10.5	10x25	/	50



YI-GAS-STER

Light Duty Caster Type D

D 款轻型脚轮

I001



Housing:

Made of pressed steel, zinc plated double ballrace swivel head

Wheel:

Material: PVC/Rubber/PP/TPR

Bearing type: Plain bearing/Ball bearing

支架:

冲压镀锌铁支架, 双玻盘

轮子:

材料: 聚氯乙烯 / 橡胶 / 塑料 / 热塑性橡胶

轴承类型: 滑动轴承 / 滚珠轴承

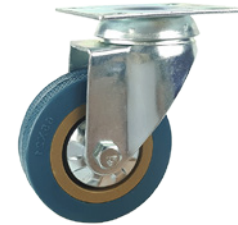

I001DXXXXPVCP

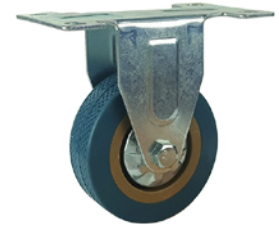

I001DXXXXPVCPF

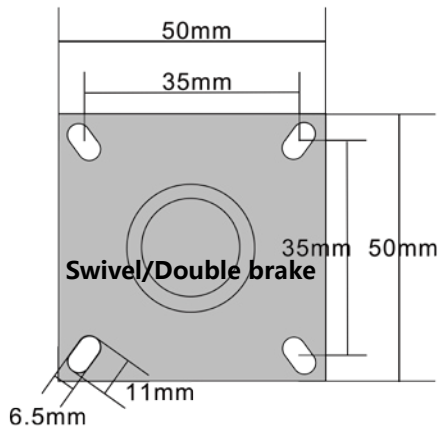

50mm caster plate size

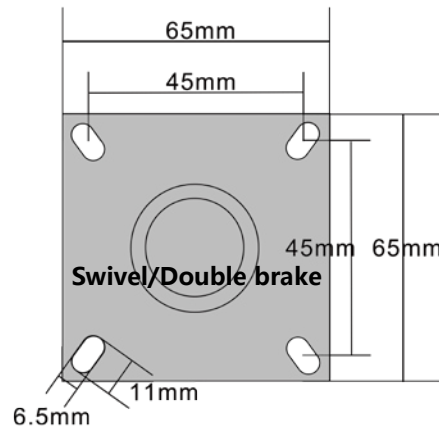

65/75mm caster plate size

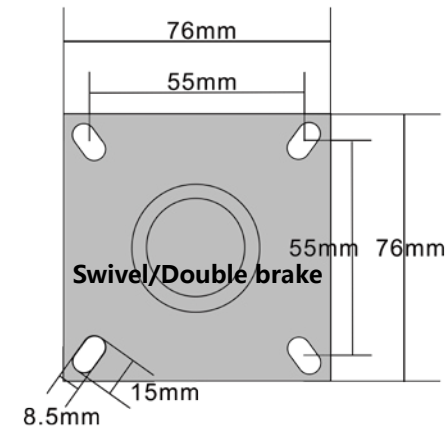

100/125mm caster plate size

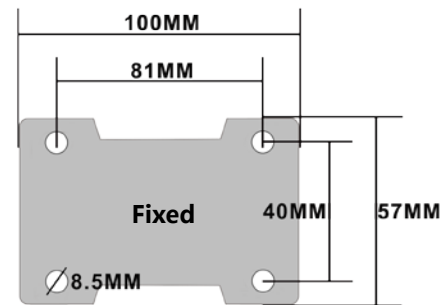
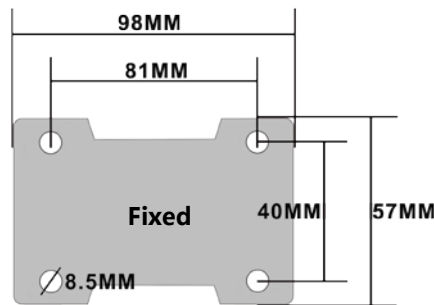
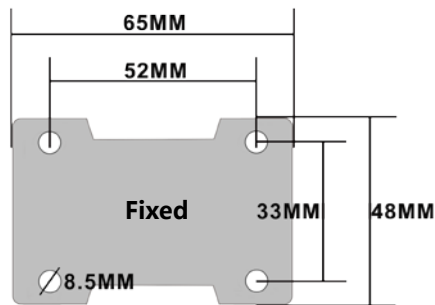

YI-CAS-STER

Light Duty Caster Type D D 款轻型脚轮

I001



I001DXXXPVCPB



I001DXXXPVCD



I001DXXXPVCD



I001DXXXPVCT



I001DXXXPVCTB

Wheel Material	Model Number													
PVC + PP Core 塑芯 聚氯乙烯	I001D050PVCP	50x17	69	50x50	35x35	11x6.5	65x48	52x33	8.5	10.5	10x25	≡	30	
	I001D065PVCP	65x21	88	65x65	45x45	11x6.5	98x57	81x40	8.5	10.5	10x25	≡	40	
	I001D075PVCP	75x21	100	65x65	45x45	11x6.5	98x57	81x40	8.5	10.5	12x30	≡	45	
	I001D100PVCP	100x27	130	76x76	55x55	15x8.5	100x57	81x40	8.5	10.5	12x30	≡	55	
	I001D125PVCP	125x27	155	76x76	55x55	15x8.5	100x57	81x40	8.5	10.5	12x30	≡	65	
PP 塑料	I001D050PPP	50x17	69	50x50	35x35	11x6.5	65x48	52x33	8.5	10.5	10x25	≡	30	
	I001D065PPP	65x21	88	65x65	45x45	11x6.5	98x57	81x40	8.5	10.5	10x25	≡	40	
	I001D075PPP	75x21	100	65x65	45x45	11x6.5	98x57	81x40	8.5	10.5	12x30	≡	45	
	I001D100PPP	100x27	130	76x76	55x55	15x8.5	100x57	81x40	8.5	10.5	12x30	≡	55	
TPR + PP Core 塑芯 热塑橡胶	I001D050TPRP	50x17	69	50x50	35x35	11x6.5	65x48	52x33	8.5	10.5	10x25	≡	30	
	I001D065TPRP	65x21	88	65x65	45x45	11x6.5	98x57	81x40	8.5	10.5	10x25	≡	40	
	I001D075TPRP	75x21	100	65x65	45x45	11x6.5	98x57	81x40	8.5	10.5	12x30	≡	45	
	I001D100TPRP	100x27	130	76x76	55x55	15x8.5	100x57	81x40	8.5	10.5	12x30	≡	55	
	I001D125TPRP	125x27	155	76x76	55x55	15x8.5	100x57	81x40	8.5	10.5	14x30	≡	65	
PVC + PP Core 塑芯 聚氯乙烯	I001D050PVC1P	50x17	69	50x50	35x35	11x6.5	65x48	52x33	8.5	10.5	10x25	⊗	40	

Y-L-CAS-STER

Light Duty Caster Type E E 款轻型脚轮

I001



Housing:

Made of pressed steel, zinc plated double ballrace swivel head

Wheel:

Material: TPR/PP/PVC
Type : Twin-wheel

支架:

冲压镀锌铁支架, 双玻盘

轮子:

材料: 热塑性橡胶 / 塑料 / 聚氯乙烯
类型: 双轮



I001EXXXPVC1P-TW



I001EXXXPVC1D-TW



I001EXXXPVC1T-TW



I001EXXXPVC1PB2-TW



I001EXXXPVC1DB2-TW



I001EXXXPVC1TB2-TW



Wheel Material	Model Number												
PVC + PP Core 塑芯 聚氯乙烯	I001E050PVC1P-TW	50x19	75	60x60	40x40	12.5x6	10.5	10x25	45	/	70		
	I001E075PVC1P-TW	75x23	101	65x65	45x45	14.5x8	12.5	12x30	58	/	90		

Y1-CASSTER

Light Duty Caster Type E E 款轻型脚轮

I001



YLCAS-TEER

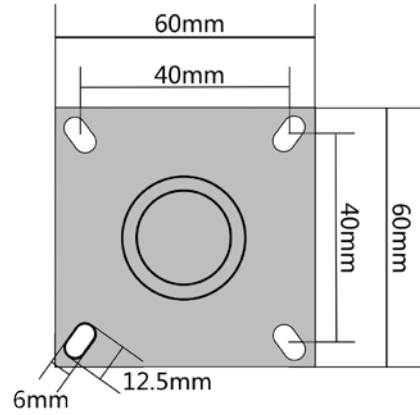

I001E050XXXP /B2-TW

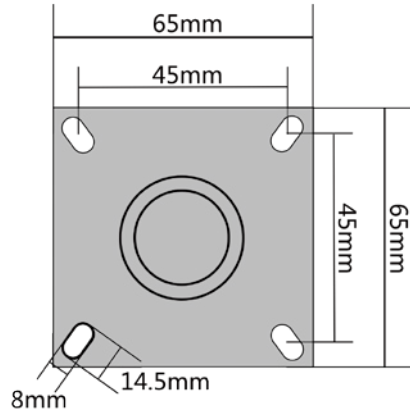

I001E075XXXP /B2-TW



Wheel Material	Model Number											
TPR + PP Core 塑芯 热塑橡胶	I001E050TPRP-TW	50x19	75	60x60	40x40	12.5x6	10.5	10x25	45	/	60	
	I001E075TPRP-TW	75x23	101	65x65	45x45	14.5x8	12.5	12x30	58	/	80	
PP 塑料	I001E050PPP-TW	50x19	75	60x60	40x40	12.5x6	10.5	10x25	45	/	70	
	I001E075PPP-TW	75x23	101	65x65	45x45	14.5x8	12.5	12x30	58	/	90	
PVC + PP Core 塑芯 聚氯乙烯	I001E050PVCP-TW	50x19	75	60x60	40x40	12.5x6	10.5	10x25	45	/	70	
	I001E075PVCP-TW	75x23	101	65x65	45x45	14.5x8	12.5	12x30	58	/	90	

Light Duty Caster Type G G 款轻型脚轮

I001



Housing:

Made of pressed steel, zinc plated
single ballrace swivel head (50/65/75mm)
double ballrace swivel head (100mm)

Wheel:

Material: Rubber/Nylon
Bearing type: No bearing

支架:

冲压铁支架, 镀锌
单玻盘 (50/65/75mm), 双玻盘 (100mm)

轮子:

材料: 橡胶 / 尼龙
轴承类型: 无轴承



I001GXXXRSW



I001GXXXRP



I001GXXXRPF



I001GXXXRPB1

Y1-CAS-STER



Wheel Material	Model Number											
Hard Rubber 硬橡胶	I001G050RSW	I001G050RP	50x22	66	60x48	46x35	60x42	45x25	6.3	/	38	
	I001G065RSW	I001G065RP	65x24	84	70x58	55x42	70x46	55x27	8.6	/	53	
	I001G075RSW	I001G075RP	75x25	94	70x58	55x42	70x46	55x27	8.6	/	58	
	I001G100RSW	I001G100RP	100x27	121	100x58	82x40	100x58	82x40	8.6	/	60	
PA 尼龙	I001G050PASW	I001G050PAP	50x22	66	60x48	46x35	60x42	45x25	6.3	/	60	
	I001G065PASW	I001G065PAP	65x24	84	70x58	55x42	70x46	55x27	8.6	/	80	
	I001G075PASW	I001G075PAP	75x25	94	70x58	55x42	70x46	55x27	8.6	/	80	
	I001G100PASW	I001G100PAP	100x27	121	100x58	82x40	100x58	82x40	8.6	/	100	



YL-CAS-STER

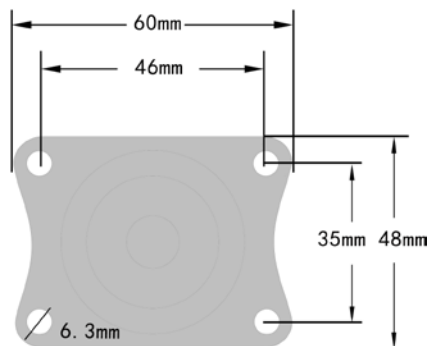

I001G050XXXP /B1

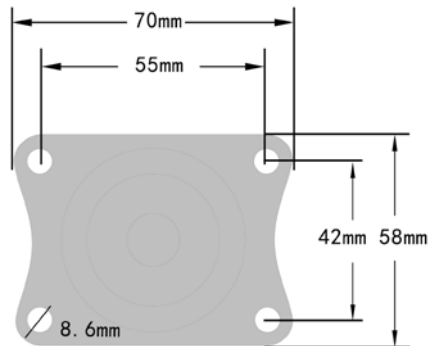

I001G065XXXP /B1
I001G075XXXP /B1

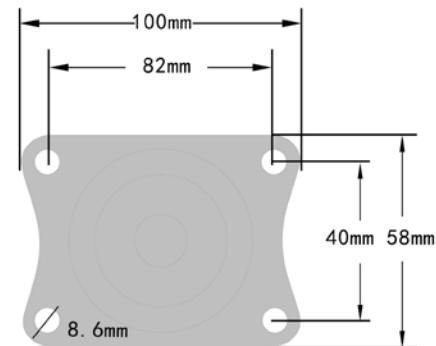

I001G100XXXP /B1

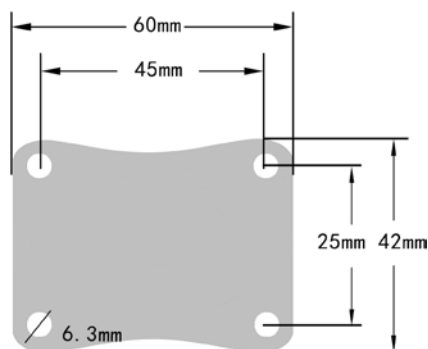

I001G050XXXPF

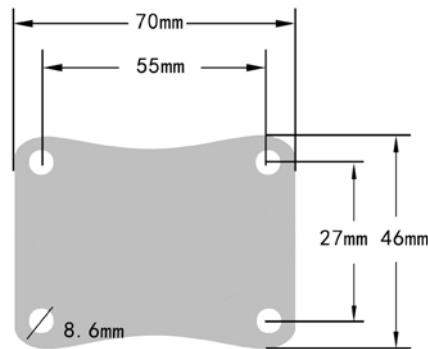

I001G065XXXPF
I001G075XXXPF

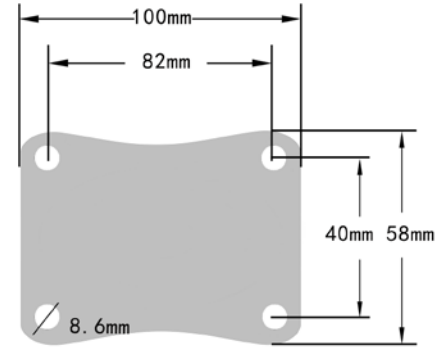

I001G100XXXPF

I002



I002 Series Medium Duty Caster Wheel Types Preview

I002 中型脚轮系列款式预览

Y1-CAS-STER

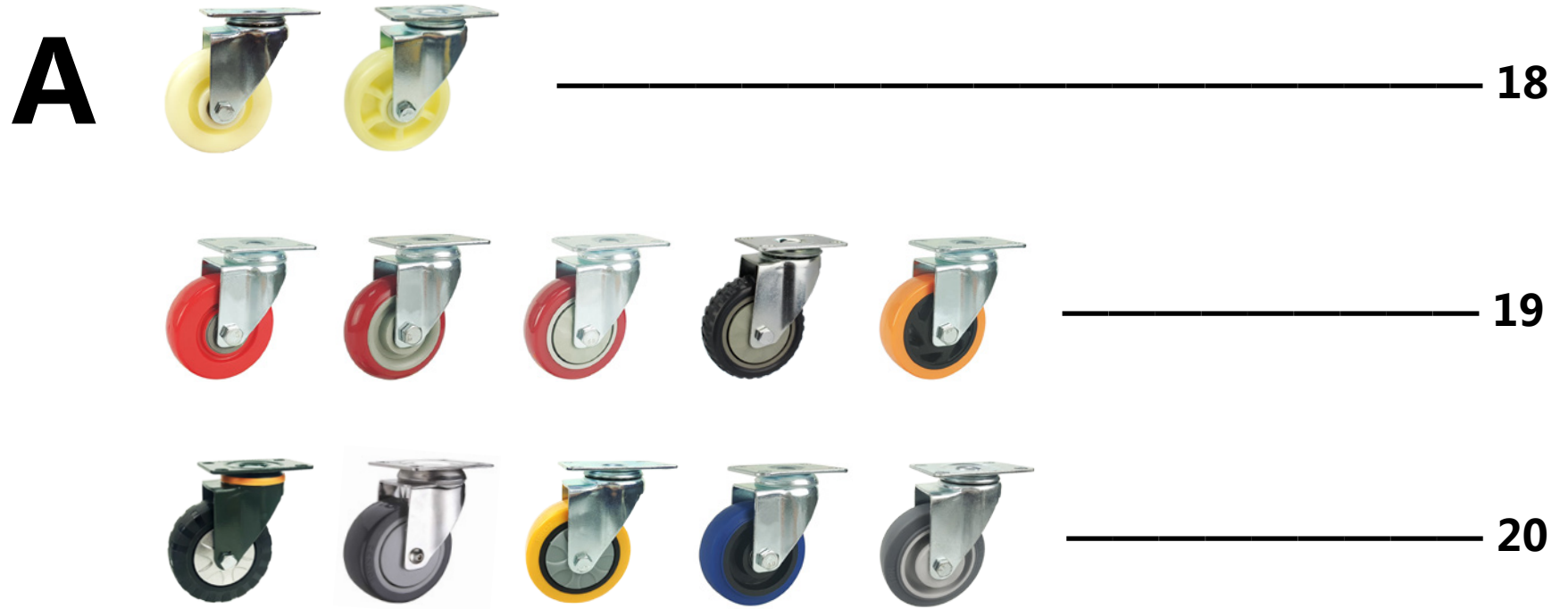

Medium Duty Caster 中型脚轮

I002



YI-GAS-STER



21



22

B



24

Medium Duty Caster Type A A 款中型脚轮

I002

**Housing:**

Made of pressed steel, zinc plated,
double ballrace swivel head

Wheel:

Material: PP/PVC/PU/TPR/Rubber.....

Bearing type: Precision double ball bearing
Roller bearing/Plain bearing

支架:

冲压镀锌铁支架, 双玻盘

轮子:

材料: 塑料 / 聚氯乙烯 / 聚氨酯 / 热塑性橡胶 / 橡胶.....

轴承类型: 精密双滚珠轴承 / 滚针轴承 / 滑动轴承



I002AXXXPPWWA



I002AXXXPPP



I002AXXXPPPF



I002AXXXPPPB



I002AXXXPPT



I002AXXXPPTB

YI-GAS-TER

Medium Duty Caster Type A A 款中型脚轮

I002

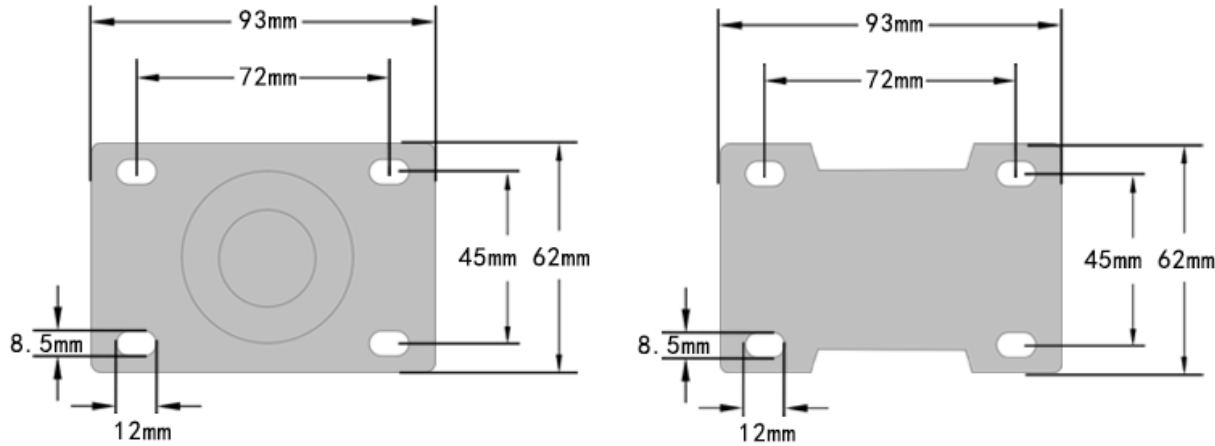

This series all size of swivel/double brake and fixed caster wheel share the same plate size, bolt hole spacing and bolt hole diameter.

此系列各尺寸活动、双刹及固定脚轮底板和孔距、孔径一致。



Side brake

可选择平板边刹脚轮



Fork with bolt hole is available

可选择孔顶支架



Fork with stem is available

可选择插杆支架



Wheel Material	Model Number												
PP 塑料	I002A060PPWWA	I002A060PPP	60x32	92	93x62	72x45	93x62	72x45	12x8.5	12x30		60	
	I002A075PPWWA	I002A075PPP	75x32	105	93x62	72x45	93x62	72x45	12x8.5	12x30		80	
	I002A100PPWWA	I002A100PPP	100x32	130	93x62	72x45	93x62	72x45	12x8.5	12x30		90	
	I002A125PPWWA	I002A125PPP	125x32	155	93x62	72x45	93x62	72x45	12x8.5	12x30		100	
PP 塑料	I002A075PP1WWA	I002A075PP1P	75x32	105	93x62	72x45	93x62	72x45	12x8.5	12x30		80	
	I002A100PP1WWA	I002A100PP1P	100x32	130	93x62	72x45	93x62	72x45	12x8.5	12x30		90	
	I002A125PP1WWA	I002A125PP1P	125x32	155	93x62	72x45	93x62	72x45	12x8.5	12x30		100	

XL-CAS-STER

Medium Duty Caster Type A A 款中型脚轮

I002



Y-1-CAS-STER



Wheel Material	Model Number											
PVC + PP Core 塑芯 聚氯乙烯	I002A075PVCWWA	I002A075PVCPC	75x32	105	93x62	72x45	93x62	72x45	12x8.5	12x30		80
	I002A100PVCWWA	I002A100PVCPC	100x32	130	93x62	72x45	93x62	72x45	12x8.5	12x30		90
	I002A125PVCWWA	I002A125PVCPC	125x32	155	93x62	72x45	93x62	72x45	12x8.5	12x30		100
PVC + PP Core 塑芯 聚氯乙烯	I002A060PVC1WWA	I002A060PVC1P	60x32	92	93x62	72x45	93x62	72x45	12x8.5	12x30		60
	I002A075PVC1WWA	I002A075PVC1P	75x32	105	93x62	72x45	93x62	72x45	12x8.5	12x30		80
	I002A100PVC1WWA	I002A100PVC1P	100x32	130	93x62	72x45	93x62	72x45	12x8.5	12x30		90
	I002A125PVC1WWA	I002A125PVC1P	125x32	155	93x62	72x45	93x62	72x45	12x8.5	12x30		100
	I002A150PVC1WWA	I002A150PVC1P	150x32	182	93x62	72x45	93x62	72x45	12x8.5	12x30		150
PVC + PP Core 塑芯 聚氯乙烯	I002A075PVC2WWA	I002A075PVC2P	75x32	105	93x62	72x45	93x62	72x45	12x8.5	12x30		60
	I002A100PVC2WWA	I002A100PVC2P	100x32	130	93x62	72x45	93x62	72x45	12x8.5	12x30		70
	I002A125PVC2WWA	I002A125PVC2P	125x32	155	93x62	72x45	93x62	72x45	12x8.5	12x30		80
PVC + PP Core 塑芯 聚氯乙烯	I002A075PVC3WWA	I002A075PVC3P	75x32	105	93x62	72x45	93x62	72x45	12x8.5	12x30		60
	I002A100PVC3WWA	I002A100PVC3P	100x32	130	93x62	72x45	93x62	72x45	12x8.5	12x30		70
	I002A125PVC3WWA	I002A125PVC3P	125x32	155	93x62	72x45	93x62	72x45	12x8.5	12x30		80

Medium Duty Caster Type A A 款中型脚轮

1002

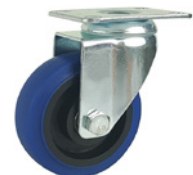

Wheel Material	Model Number											
PVC + PP Core 塑芯 聚氯乙烯	I002A060PVC4WWA	I002A060PVC4P	60x32	92	93x62	72x45	93x62	72x45	12x8.5	12x30		60
	I002A075PVC4WWA	I002A075PVC4P	75x32	105	93x62	72x45	93x62	72x45	12x8.5	12x30		80
	I002A100PVC4WWA	I002A100PVC4P	100x32	130	93x62	72x45	93x62	72x45	12x8.5	12x30		90
	I002A125PVC4WWA	I002A125PVC4P	125x32	155	93x62	72x45	93x62	72x45	12x8.5	12x30		100
	I002A150PVC4WWA	I002A150PVC4P	150x32	182	93x62	72x45	93x62	72x45	12x8.5	12x30		150
PU + PP Core 塑芯聚氨酯	I002A075PUWWA	I002A075PUP	75x32	105	93x62	72x45	93x62	72x45	12x8.5	12x30		90
	I002A100PUWWA	I002A100PUP	100x32	130	93x62	72x45	93x62	72x45	12x8.5	12x30		110
	I002A125PUWWA	I002A125PUP	125x32	155	93x62	72x45	93x62	72x45	12x8.5	12x30		130
PU + PP Core 塑芯聚氨酯	I002A075PU1WWA	I002A075PU1P	75x32	105	93x62	72x45	93x62	72x45	12x8.5	12x30		90
	I002A100PU1WWA	I002A100PU1P	100x32	130	93x62	72x45	93x62	72x45	12x8.5	12x30		110
	I002A125PU1WWA	I002A125PU1P	125x32	155	93x62	72x45	93x62	72x45	12x8.5	12x30		135
PU + PP Core 塑芯聚氨酯	I002A075PU2WWA	I002A075PU2P	75x32	105	93x62	72x45	93x62	72x45	12x8.5	12x30		90
	I002A100PU2WWA	I002A100PU2P	100x32	130	93x62	72x45	93x62	72x45	12x8.5	12x30		110
	I002A125PU2WWA	I002A125PU2P	125x32	155	93x62	72x45	93x62	72x45	12x8.5	12x30		135
TPR + PP Core 塑芯 热塑橡胶	I002A075TPRWWA	I002A075TPRP	75x32	105	93x62	72x45	93x62	72x45	12x8.5	12x30		80
	I002A100TPRWWA	I002A100TPRP	100x32	130	93x62	72x45	93x62	72x45	12x8.5	12x30		90
	I002A125TPRWWA	I002A125TPRP	125x32	155	93x62	72x45	93x62	72x45	12x8.5	12x30		100



Y1-GAS-STER

Medium Duty Caster Type A A 款中型脚轮

1002



Y-1-CAS-STER



Wheel Material	Model Number											
TPR + PP Core 塑芯 热塑橡胶	I002A075TPR1WWA	I002A075TPR1P	75x32	105	93x62	72x45	93x62	72x45	12x8.5	12x30		80
	I002A100TPR1WWA	I002A100TPR1P	100x32	130	93x62	72x45	93x62	72x45	12x8.5	12x30		90
	I002A125TPR1WWA	I002A125TPR1P	125x32	155	93x62	72x45	93x62	72x45	12x8.5	12x30		100
TPR + PP Core 塑芯 热塑橡胶	I002A075TPR2WWA	I002A075TPR2P	75x32	105	93x62	72x45	93x62	72x45	12x8.5	12x30		80
	I002A100TPR2WWA	I002A100TPR2P	100x32	130	93x62	72x45	93x62	72x45	12x8.5	12x30		100
	I002A125TPR2WWA	I002A125TPR2P	125x32	155	93x62	72x45	93x62	72x45	12x8.5	12x30		110
TPR + PP Core 塑芯 热塑橡胶	I002A075TPR3WWA	I002A075TPR3P	75x32	105	93x62	72x45	93x62	72x45	12x8.5	12x30		80
	I002A100TPR3WWA	I002A100TPR3P	100x32	130	93x62	72x45	93x62	72x45	12x8.5	12x30		100
	I002A125TPR3WWA	I002A125TPR3P	125x32	155	93x62	72x45	93x62	72x45	12x8.5	12x30		110
TPR + PP Core 塑芯 热塑橡胶	I002A075TPR4WWA	I002A075TPR4P	75x32	105	93x62	72x45	93x62	72x45	12x8.5	12x30		80
	I002A100TPR4WWA	I002A100TPR4P	100x32	130	93x62	72x45	93x62	72x45	12x8.5	12x30		90
	I002A125TPR4WWA	I002A125TPR4P	125x32	155	93x62	72x45	93x62	72x45	12x8.5	12x30		100
Hard Rubber 硬橡胶	I002A075HRWWA	I002A075HRP	75x28	105	93x62	72x45	93x62	72x45	12x8.5	12x30		70
	I002A100HRWWA	I002A100HRP	100x32	130	93x62	72x45	93x62	72x45	12x8.5	12x30		80
	I002A125HRWWA	I002A125HRP	125x32	155	93x62	72x45	93x62	72x45	12x8.5	12x30		90

Medium Duty Caster Type A A 款中型脚轮

I002



Wheel Material	Model Number												
Elastic Rubber + PP Core 塑芯 弹力橡胶	I002A075ERWWA	I002A075ERP	75x33	105	93x62	72x45	93x62	72x45	12x8.5	12x30		60	
	I002A100ERWWA	I002A100ERP	100x33	130	93x62	72x45	93x62	72x45	12x8.5	12x30		80	
	I002A125ERWWA	I002A125ERP	125x34	155	93x62	72x45	93x62	72x45	12x8.5	12x30		90	
Elastic Rubber + PP Core 塑芯 弹力橡胶	I002A075ER1WWA	I002A075ER1P	75x35	105	93x62	72x45	93x62	72x45	12x8.5	12x30		60	
	I002A100ER1WWA	I002A100ER1P	100x35	130	93x62	72x45	93x62	72x45	12x8.5	12x30		70	
	I002A125ER1WWA	I002A125ER1P	125x35	155	93x62	72x45	93x62	72x45	12x8.5	12x30		80	
Cast Iron 铸铁	I002A075CWWA	I002A075CP	75x30	105	93x62	72x45	93x62	72x45	12x8.5	12x30	/	100	
	I002A100CWWA	I002A100CP	100x32	130	93x62	72x45	93x62	72x45	12x8.5	12x30	/	120	
PU + Cast Iron Core 铁芯聚氨酯	I002A060CPUWWA	I002A060CPUP	60x32	92	93x62	72x45	93x62	72x45	12x8.5	12x30		80	
	I002A075CPUWWA	I002A075CPUP	75x32	105	93x62	72x45	93x62	72x45	12x8.5	12x30		100	
	I002A100CPUWWA	I002A100CPUP	100x32	130	93x62	72x45	93x62	72x45	12x8.5	12x30		110	
	I002A125CPUWWA	I002A125CPUP	125x32	155	93x62	72x45	93x62	72x45	12x8.5	12x30		130	
PU + Aluminium Core 铝芯聚氨酯	I002A075APUWWA	I002A075APUP	75x32	105	93x62	72x45	93x62	72x45	12x8.5	12x30		100	
	I002A100APUWWA	I002A100APUP	100x32	130	93x62	72x45	93x62	72x45	12x8.5	12x30		120	
	I002A125APUWWA	I002A125APUP	125x32	155	93x62	72x45	93x62	72x45	12x8.5	12x30		150	



Y-L-GAS-STER

Medium Duty Caster Type B B 款中型脚轮

1002

**Housing:**

Made of pressed steel, zinc plated
double ballrace swivel head

Wheel:

Material: Polymer/TPR/Elastic Rubber

Bearing type: Precision double ball bearing

支架:

冲压镀锌铁支架, 双玻盘

轮子:

材料: 共聚 / 热塑性橡胶 / 弹力橡胶

类型: 精密双滚珠轴承

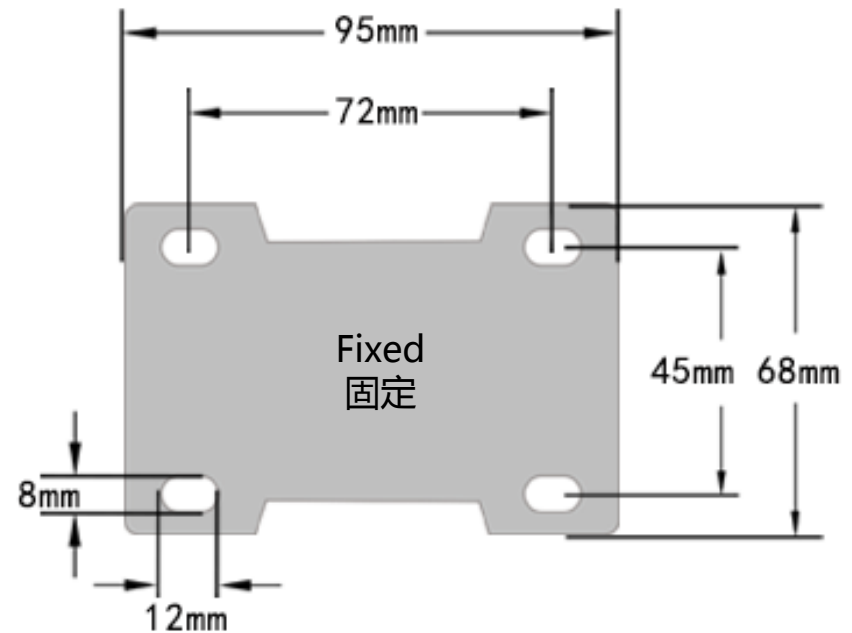
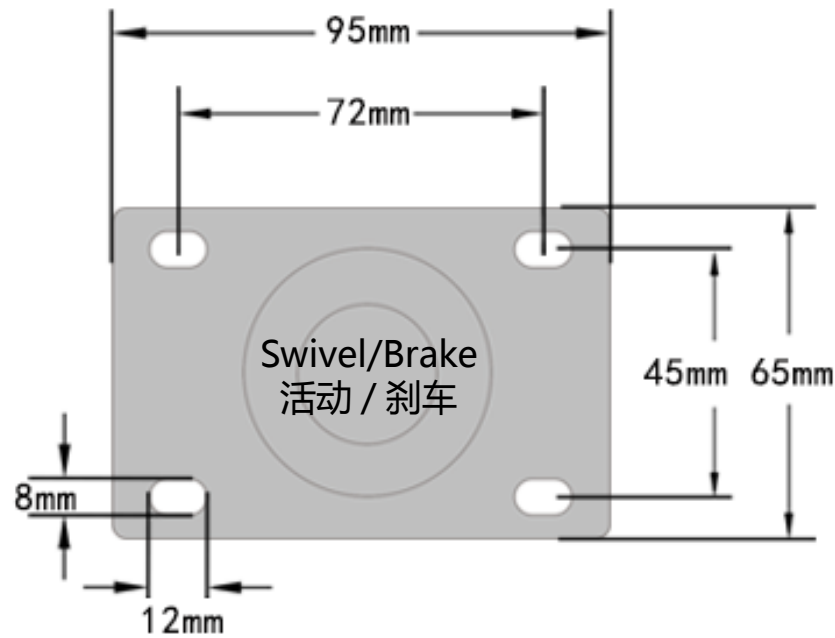

YI-CAS-TER

Medium Duty Caster Type B B 款中型脚轮

I002



I002BXXXFP



I002BXXXFPF



I002BXXXFPB



Wheel Material	Model Number										
FP 共聚	I002B075FPP	75x35	105	93x62	72x45	95x68	72x45	12x8	12x30		90
	I002B100FPP	100x35	130	93x62	72x45	95x68	72x45	12x8	12x30		110
	I002B125FPP	125x35	155	93x62	72x45	95x68	72x45	12x8	12x30		130
TPR + PP Core 塑芯 热塑橡胶	I002B075TPRP	75x35	105	93x62	72x45	95x68	72x45	12x8	12x30		80
	I002B100TPRP	100x35	130	93x62	72x45	95x68	72x45	12x8	12x30		100
	I002B125TPRP	125x35	155	93x62	72x45	95x68	72x45	12x8	12x30		120
Elastic Rubber + PP Core 塑芯 弹力橡胶	I002B075ERP	75x32	105	93x62	72x45	95x68	72x45	12x8	12x30		70
	I002B100ERP	100x32	130	93x62	72x45	95x68	72x45	12x8	12x30		90
	I002B125ERP	125x32	155	93x62	72x45	95x68	72x45	12x8	12x30		100

YIGASSTER

Medium Heavy Duty Caster 中重型脚轮

I003



Housing:

Made of pressed steel, electrophoresis finished, double ballrace swivel head

Wheel:

Material: PP/PU/TPR

Bearing type: Precision double ball bearing

支架:

冲压电泳铁支架, 双玻盘

轮子:

材料: 塑料 / 聚氨酯 / 热塑性橡胶

类型: 精密双滚珠轴承



I003AXXXPPP



I003AXXXPPPF



I003AXXXPPPB2

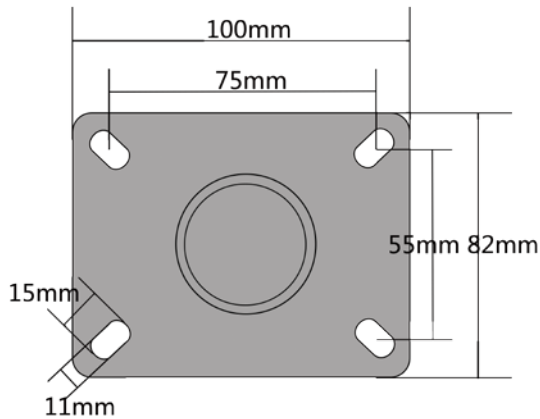

I003A075XXXP /F/B2

I003A100XXXP /F/B2

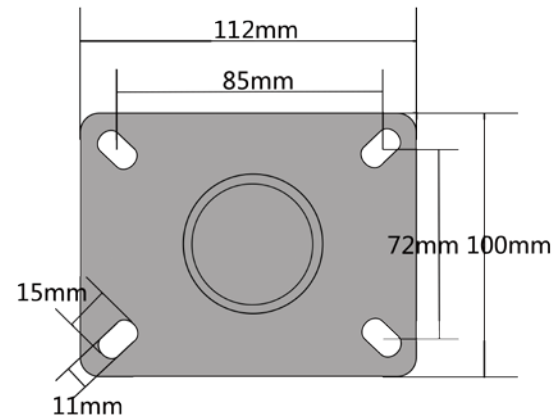

I003A125XXXP /F/B2

I003A150XXXP /F/B2

Y-1-CAS-STER



Y-L-GAS-STER



Wheel Material	Model Number							
PP 塑料	I003A100PPP	100x40	135	100x82	75x55	15x11		180
	I003A125PPP	125x40	165	112x100	85x72	15x11		220
	I003A150PPP	150x40	190	112x100	85x72	15x11		250
PU + PP Core 塑芯聚氨酯	I003A075PUP	75x40	110	100x82	75x55	15x11		150
	I003A100PUP	100x40	135	100x82	75x55	15x11		180
	I003A125PUP	125x40	165	112x100	85x72	15x11		220
	I003A150PUP	150x40	190	112x100	85x72	15x11		250
PU + PP Core 塑芯聚氨酯	I003A075PU1P	75x40	110	100x82	75x55	15x11		150
	I003A100PU1P	100x40	135	100x82	75x55	15x11		180
	I003A125PU1P	125x40	165	112x100	85x72	15x11		220
	I003A150PU1P	150x40	190	112x100	85x72	15x11		250
TPR + PP Core 塑芯 热塑橡胶	I003A100TPRP	100x40	135	100x82	75x55	15x11		130
	I003A125TPRP	125x40	165	112x100	85x72	15x11		180
	I003A150TPRP	150x40	190	112x100	85x72	15x11		230

I004

I004 Series Heavy Duty Caster Wheel Types Preview

I004 重型脚轮系列款式预览



Y1-CAS-STER

A



_____ 30



_____ 31



_____ 32



_____ 33







_____ 34



_____ 35



_____ 36

B		_____	38
C		_____	39
		_____	40
D		_____	41
E		_____	42
K		_____	43- 44
F		_____	46



YI-GAS-STER

Heavy Duty Caster Type A A 款重型脚轮

1004

**Housing:**

Solid steel bilateral welded construction, double ballrace swivel head, zinc plated

Wheel:

Material: PP/PVC/PU/TPR.....

Bearing type: Precision double ball bearing / Roller bearing

支架:

双边焊接铁支架, 镀锌处理, 双玻盘

轮子:

材料: 塑料 / 聚氯乙烯 / 聚氨酯

/ 热塑性橡胶.....
类型: 精密双滚珠轴承 / 滚针轴承



Electroplating finish is available
支架可电泳处理



Yellow zinc is available
支架可镀黄锌

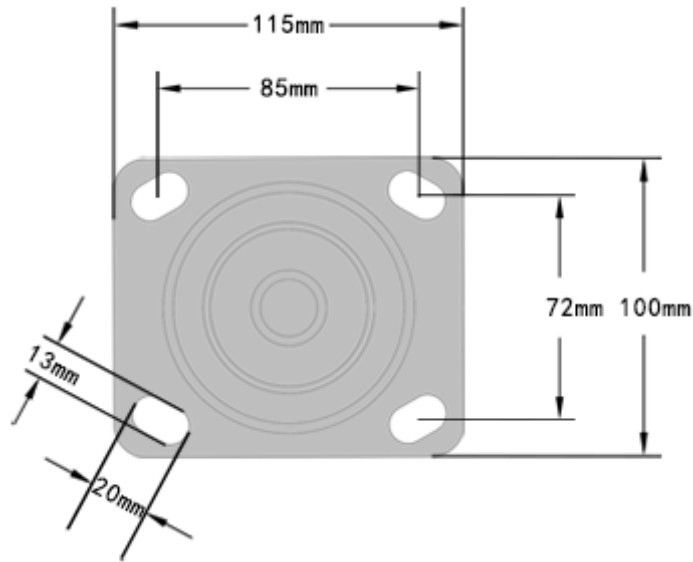

I004A100XXXP /B/B1
I004A125XXXP /B/B1
I004A150XXXP /B/B1
I004A200XXXP /B/B1

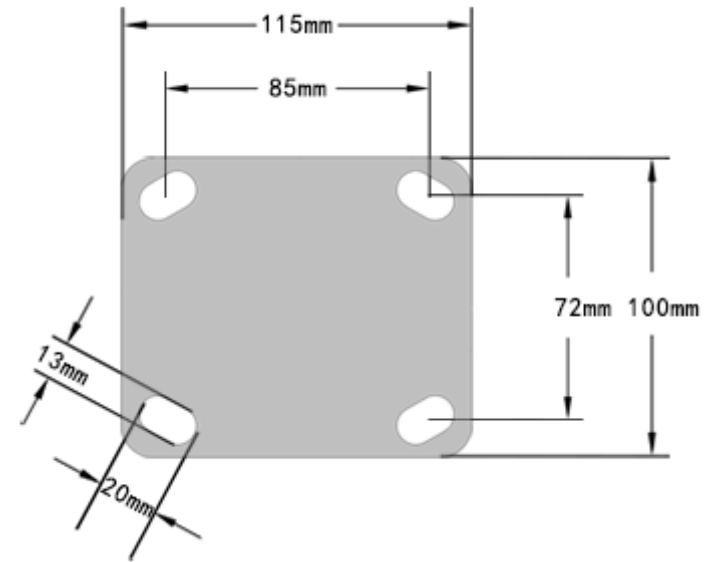

I004A100XXPF
I004A125XXPF
I004A150XXPF
I004A200XXPF

Y1-CAS-STER

Heavy Duty Caster Type A A 款重型脚轮

I004



I004AXXXPPWWA



I004AXXXPPP



I004AXXXPPPF



I004AXXXPPPB1



I004AXXXPPPB



Wheel Material	Model Number								
PP 塑料	I004A100PPWWA	I004A100PPP	100x42	142	115x100	85x72	20x13		200
	I004A125PPWWA	I004A125PPP	125x42	167	115x100	85x72	20x13		230
	I004A150PPWWA	I004A150PPP	150x42	195	115x100	85x72	20x13		280
	I004A200PPWWA	I004A200PPP	200x42	237	115x100	85x72	20x13		300
PP 塑料	I004A100PP1WWA	I004A100PP1P	100x50	142	115x100	85x72	20x13		230
	I004A125PP1WWA	I004A125PP1P	125x50	166	115x100	85x72	20x13		280
	I004A150PP1WWA	I004A150PP1P	150x50	190	115x100	85x72	20x13		300
	I004A200PP1WWA	I004A200PP1P	200x50	240	115x100	85x72	20x13		320
PP 塑料	I004A100PP2WWA	I004A100PP2P	100x50	142	115x100	85x72	20x13		300
	I004A125PP2WWA	I004A125PP2P	125x50	167	115x100	85x72	20x13		350
	I004A150PP2WWA	I004A150PP2P	150x50	195	115x100	85x72	20x13		400
	I004A200PP2WWA	I004A200PP2P	200x50	240	115x100	85x72	20x13		450

YI-GAS-STER

Heavy Duty Caster Type A A 款重型脚轮

1004



Y1-CAS-TER



Wheel Material	Model Number								
FP 共聚	I004A100FPWWA	I004A100FPP	100x42	142	115x100	85x72	20x13		250
	I004A125FPWWA	I004A125FPP	125x42	166	115x100	85x72	20x13		280
	I004A150FPWWA	I004A150FPP	150x42	190	115x100	85x72	20x13		300
	I004A200FPWWA	I004A200FPP	200x42	240	115x100	85x72	20x13		350
PA 尼龙	I004A100PAWWA	I004A100PAP	100x42	142	115x100	85x72	20x13		300
	I004A125PAWWA	I004A125PAP	125x42	164	115x100	85x72	20x13		400
	I004A150PAWWA	I004A150PAP	150x42	190	115x100	85x72	20x13		500
	I004A200PAWWA	I004A200PAP	200x42	240	115x100	85x72	20x13		600
PA 尼龙	I004A100PA1WWA	I004A100PA1P	100x50	142	115x100	85x72	20x13		300
	I004A125PA1WWA	I004A125PA1P	125x50	164	115x100	85x72	20x13		400
	I004A150PA1WWA	I004A150PA1P	150x50	190	115x100	85x72	20x13		500
	I004A200PA1WWA	I004A200PA1P	200x50	240	115x100	85x72	20x13		600
PVC + PP Core 塑芯 聚氯乙烯	I004A100PVCWWA	I004A100PVCP	100x50	142	115x100	85x72	20x13		200
	I004A125PVCWWA	I004A125PVCP	125x50	166	115x100	85x72	20x13		230
	I004A150PVCWWA	I004A150PVCP	150x50	190	115x100	85x72	20x13		280
	I004A200PVCWWA	I004A200PVCP	200x50	240	115x100	85x72	20x13		300

Heavy Duty Caster Type A A 款重型脚轮

I004



Y-L-GAS-STER



Wheel Material	Model Number									
PVC + PP Core 塑芯 聚氯乙烯	I004A100PVC1WWA	I004A100PVC1P	100x50	142	115x100	85x72	20x13		200	
	I004A125PVC1WWA	I004A125PVC1P	125x50	166	115x100	85x72	20x13		230	
	I004A150PVC1WWA	I004A150PVC1P	150x50	190	115x100	85x72	20x13		280	
	I004A200PVC1WWA	I004A200PVC1P	200x50	240	115x100	85x72	20x13		300	
PVC + PP Core 塑芯 聚氯乙烯	I004A100PVC2WWA	I004A100PVC2P	100x50	142	115x100	85x72	20x13		200	
	I004A125PVC2WWA	I004A125PVC2P	125x50	166	115x100	85x72	20x13		230	
	I004A150PVC2WWA	I004A150PVC2P	150x50	190	115x100	85x72	20x13		280	
	I004A200PVC2WWA	I004A200PVC2P	200x50	240	115x100	85x72	20x13		300	
PVC + PP Core 塑芯 聚氯乙烯	I004A100PVC3WWA	I004A100PVC3P	100x50	142	115x100	85x72	20x13		200	
	I004A125PVC3WWA	I004A125PVC3P	125x50	166	115x100	85x72	20x13		230	
	I004A150PVC3WWA	I004A150PVC3P	150x50	190	115x100	85x72	20x13		280	
	I004A200PVC3WWA	I004A200PVC3P	200x50	240	115x100	85x72	20x13		300	
TPR + PP Core 塑芯 热塑橡胶	I004A100TPRWWA	I004A100TPRP	100x50	142	115x100	85x72	20x13		200	
	I004A125TPRWWA	I004A125TPRP	125x50	166	115x100	85x72	20x13		230	
	I004A150TPRWWA	I004A150TPRP	150x50	190	115x100	85x72	20x13		250	
	I004A200TPRWWA	I004A200TPRP	200x50	240	115x100	85x72	20x13		280	

Heavy Duty Caster Type A A款重型脚轮

I004



Y1-CAS-TER



Wheel Material	Model Number									
TPR + PP Core 塑芯热塑橡胶	I004A100TPR1WWA	I004A100TPR1P	100x50	142	115x100	85x72	20x13		200	
	I004A125TPR1WWA	I004A125TPR1P	125x50	166	115x100	85x72	20x13		230	
	I004A150TPR1WWA	I004A150TPR1P	150x50	190	115x100	85x72	20x13		250	
	I004A200TPR1WWA	I004A200TPR1P	200x50	240	115x100	85x72	20x13		280	
TPR + PP Core 塑芯热塑橡胶	I004A100TPR2WWA	I004A100TPR2P	100x50	142	115x100	85x72	20x13		230	
	I004A125TPR2WWA	I004A125TPR2P	125x50	164	115x100	85x72	20x13		250	
	I004A150TPR2WWA	I004A150TPR2P	150x50	190	115x100	85x72	20x13		280	
	I004A200TPR2WWA	I004A200TPR2P	200x50	240	115x100	85x72	20x13		300	
Elastic Rubber + PP Core 塑芯弹力橡胶	I004A100ERWWA	I004A100ERP	100x53	142	115x100	85x72	20x13		180	
	I004A125ERWWA	I004A125ERP	125x53	166	115x100	85x72	20x13		200	
	I004A150ERWWA	I004A150ERP	150x53	190	115x100	85x72	20x13		230	
	I004A200ERWWA	I004A200ERP	200x53	240	115x100	85x72	20x13		250	
Elastic Rubber + PP Core 塑芯弹力橡胶	I004A100ER1WWA	I004A100ER1P	100x53	142	115x100	85x72	20x13		200	
	I004A125ER1WWA	I004A125ER1P	125x53	166	115x100	85x72	20x13		230	
	I004A150ER1WWA	I004A150ER1P	150x53	190	115x100	85x72	20x13		280	
	I004A200ER1WWA	I004A200ER1P	200x53	240	115x100	85x72	20x13		300	

Heavy Duty Caster Type A A 款重型脚轮

I004



Y-L-GAS-STER

Wheel Material	Model Number									
Cast Iron V-Groove 铸铁 V 槽轮	I004A100CVWWA	I004A100CVP	100x50	142	115x100	85x72	20x13		400	
	I004A125CVWWA	I004A125CVP	125x50	166	115x100	85x72	20x13		450	
	I004A150CVWWA	I004A150CVP	150x50	195	115x100	85x72	20x13		500	
	I004A200CVWWA	I004A200CVP	200x50	240	115x100	85x72	20x13		550	
Cast Iron 铸铁	I004A100C1WWA	I004A100C1P	100x50	142	115x100	85x72	20x13		200	
	I004A125C1WWA	I004A125C1P	125x50	166	115x100	85x72	20x13		230	
	I004A150C1WWA	I004A150C1P	150x50	195	115x100	85x72	20x13		280	
	I004A200C1WWA	I004A200C1P	200x50	240	115x100	85x72	20x13		300	
Cast Iron 实心铸铁	I004A100C2WWA	I004A100C2P	100x50	142	115x100	85x72	20x13		200	
	I004A125C2WWA	I004A125C2P	125x50	166	115x100	85x72	20x13		230	
	I004A150C2WWA	I004A150C2P	150x50	195	115x100	85x72	20x13		280	
	I004A200C2WWA	I004A200C2P	200x50	240	115x100	85x72	20x13		300	
Elastic Rubber + Cast Iron Core 铁芯弹力橡胶	I004A100CERWWA	I004A100CERP	100x42	141	115x100	85x72	20x13		180	
	I004A125CERWWA	I004A125CERP	125x42	161	115x100	85x72	20x13		200	
	I004A150CERWWA	I004A150CERP	150x42	192	115x100	85x72	20x13		230	
	I004A200CERWWA	I004A200CERP	200x42	232	115x100	85x72	20x13		250	



Heavy Duty Caster Type A A 款重型脚轮

I004



Y1-CAS-TER



Wheel Material	Model Number								
Rubber + Cast Iron Core 铁芯橡胶	I004A100CRWWA	I004A100CRP	100x50	142	115x100	85x72	20x13		180
	I004A125CRWWA	I004A125CRP	125x50	164	115x100	85x72	20x13		200
	I004A150CRWWA	I004A150CRP	150x50	190	115x100	85x72	20x13		230
	I004A200CRWWA	I004A200CRP	200x50	240	115x100	85x72	20x13		250
PU + Cast Iron Core 铁芯聚氨酯	I004A100CPUWWA	I004A100CPUP	100x50	142	115x100	85x72	20x13		250
	I004A125CPUWWA	I004A125CPUP	125x50	166	115x100	85x72	20x13		300
	I004A150CPUWWA	I004A150CPUP	150x50	195	115x100	85x72	20x13		320
	I004A200CPUWWA	I004A200CPUP	200x50	240	115x100	85x72	20x13		380
PU + Cast Iron Core 铁芯聚氨酯	I004A100CPU1WWA	I004A100CPU1P	100x50	142	115x100	85x72	20x13		280
	I004A125CPU1WWA	I004A125CPU1P	125x50	166	115x100	85x72	20x13		300
	I004A150CPU1WWA	I004A150CPU1P	150x50	195	115x100	85x72	20x13		350
	I004A200CPU1WWA	I004A200CPU1P	200x50	240	115x100	85x72	20x13		400
PU + Cast Iron Core 铁芯聚氨酯	I004A100CPU2WWA	I004A100CPU2P	100x53	142	115x100	85x72	20x13		320
	I004A125CPU2WWA	I004A125CPU2P	125x53	166	115x100	85x72	20x13		400
	I004A150CPU2WWA	I004A150CPU2P	150x53	195	115x100	85x72	20x13		450
	I004A200CPU2WWA	I004A200CPU2P	200x53	240	115x100	85x72	20x13		540

Heavy Duty Caster Type A A 款重型脚轮

I004



YI-GAS-STER

Wheel Material	Model Number									kg
Elastic Rubber + Aluminium Core 铝芯弹力橡胶	I004A125ARWWA	I004A125ARP	125x50	166	115x100	85x72	20x13		250	
	I004A150ARWWA	I004A150ARP	150x50	195	115x100	85x72	20x13		300	
	I004A200ARWWA	I004A200ARP	200x50	240	115x100	85x72	20x13		350	
PU + Aluminium Core 铝芯聚氨酯	I004A100APUWWA	I004A100APUP	100x50	142	115x100	85x72	20x13		300	
	I004A125APUWWA	I004A125APUP	125x50	166	115x100	85x72	20x13		350	
	I004A150APUWWA	I004A150APUP	150x50	195	115x100	85x72	20x13		400	
	I004A200APUWWA	I004A200APUP	200x50	240	115x100	85x72	20x13		450	
PU + Aluminium Core 铝芯聚氨酯	I004A100APU1WWA	I004A100APU1P	100x50	142	115x100	85x72	20x13		320	
	I004A125APU1WWA	I004A125APU1P	125x50	166	115x100	85x72	20x13		400	
	I004A150APU1WWA	I004A150APU1P	150x50	195	115x100	85x72	20x13		450	
	I004A200APU1WWA	I004A200APU1P	200x50	240	115x100	85x72	20x13		540	
PU + Aluminium Core 铝芯聚氨酯	I004A100APU2WWA	I004A100APU2P	100x50	142	115x100	85x72	20x13		300	
	I004A125APU2WWA	I004A125APU2P	125x50	166	115x100	85x72	20x13		350	
	I004A150APU2WWA	I004A150APU2P	150x50	195	115x100	85x72	20x13		400	
	I004A200APU2WWA	I004A200APU2P	200x50	240	115x100	85x72	20x13		450	



Heavy Duty Caster Type B B 款重型脚轮

I004



Housing:

Solid steel welded construction,
double ballrace swivel head,
yellow zinc plated

Wheel:

Material: TPR/Polyolefin
Bearing type: Precision double ball bearing

支架:

焊接铁支架, 镀黄锌处理
双玻盘

轮子:

材料: 热塑性橡胶 / 共聚
类型: 精密双滚珠轴承

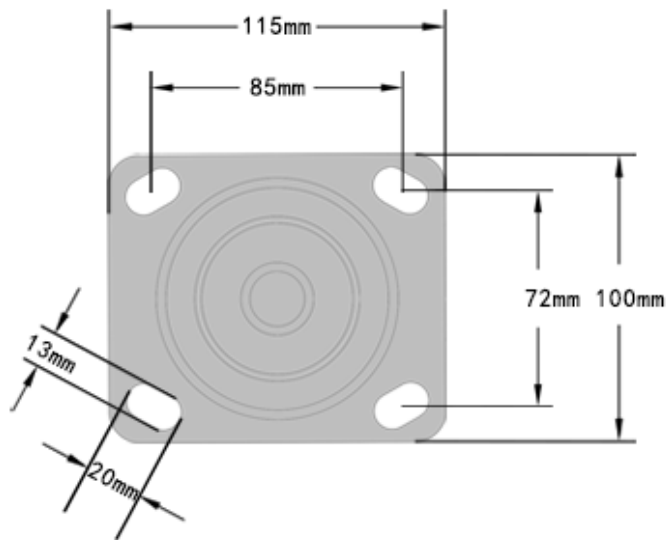

I004B100XXXP /B
I004B125XXXP /B
I004B150XXXP /B
I004B200XXXP /B

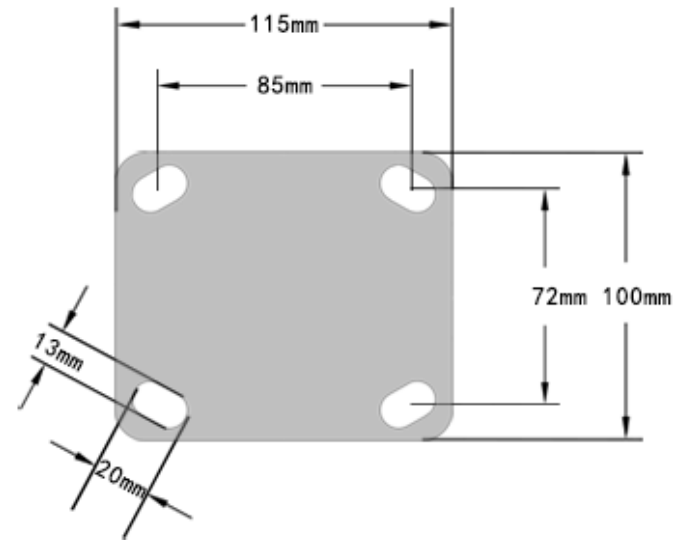

I004B100XXXPF
I004B125XXXPF
I004B150XXXPF
I004B200XXXPF

Y1-CASSTER

Heavy Duty Caster Type B B 款重型脚轮

I004



I004BXXXTPRP



I004BXXXTPRPF



Wheel Material	Model Number									
TPR + PP Core 塑芯 热塑橡胶	I004B100TPRWWA	I004B100TPRP	100x50	142	115x100	85x72	20x13		250	
	I004B125TPRWWA	I004B125TPRP	125x50	166	115x100	85x72	20x13		280	
	I004B150TPRWWA	I004B150TPRP	150x50	190	115x100	85x72	20x13		310	
	I004B200TPRWWA	I004B200TPRP	200x50	240	115x100	85x72	20x13		340	
FP 共聚	I004B100FPWWA	I004B100FPP	100x50	142	115x100	85x72	20x13		300	
	I004B125FPWWA	I004B125FPP	125x50	166	115x100	85x72	20x13		350	
	I004B150FPWWA	I004B150FPP	150x50	190	115x100	85x72	20x13		400	
	I004B200FPWWA	I004B200FPP	200x50	240	115x100	85x72	20x13		450	

YI-GAS-STER

Heavy Duty Caster Type C C 款重型脚轮

1004



Housing:
Solid steel welded construction,
double ballrace swivel head,
green powder coated

Wheel:
Material: Nylon/PP/PU
Bearing type: Precision double ball bearing

支架:
焊接铁支架, 绿色烤漆处理
双玻盘

轮子:
材料: 尼龙 / 塑料 / 聚氨酯
类型: 精密双滚珠轴承



I004CXXXPAP



I004CXXXPAPF



I004CXXXPAPB

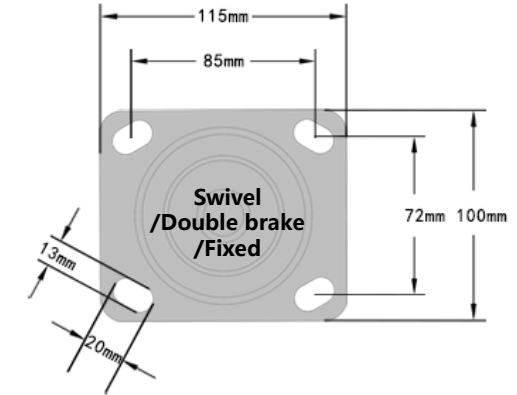

This series all size caster share the same plate size.
此系列各种材质和尺寸脚轮底板尺寸一致。

Y1-CAS-STER



Wheel Material	Model Number									
PA 尼龙	I004C100PAWWA	I004C100PAP	100x50	142	115x100	85x72	20x13		280	
	I004C125PAWWA	I004C125PAP	125x50	166	115x100	85x72	20x13		320	
	I004C150PAWWA	I004C150PAP	150x50	195	115x100	85x72	20x13		360	
	I004C200PAWWA	I004C200PAP	200x50	240	115x100	85x72	20x13		400	
PP 塑料	I004C100PPWWA	I004C100PPP	100x50	142	115x100	85x72	20x13		250	
	I004C125PPWWA	I004C125PPP	125x50	166	115x100	85x72	20x13		280	
	I004C150PPWWA	I004C150PPP	150x50	190	115x100	85x72	20x13		315	
	I004C200PPWWA	I004C200PPP	200x50	240	115x100	85x72	20x13		350	

Heavy Duty Caster Type C C 款重型脚轮

I004



Y1-CAS-STER



Wheel Material	Model Number								
PU + PP Core 塑芯聚氨酯	I004C100PUWWA	I004C100PUP	100x50	142	115x100	85x72	20x13		200
	I004C125PUWWA	I004C125PUP	125x50	166	115x100	85x72	20x13		230
	I004C150PUWWA	I004C150PUP	150x50	195	115x100	85x72	20x13		280
	I004C200PUWWA	I004C200PUP	200x50	240	115x100	85x72	20x13		300
PU + PP Core 塑芯聚氨酯	I004C100PU1WWA	I004C100PU1P	100x50	142	115x100	85x72	20x13		250
	I004C125PU1WWA	I004C125PU1P	125x50	166	115x100	85x72	20x13		280
	I004C150PU1WWA	I004C150PU1P	150x50	195	115x100	85x72	20x13		320
	I004C200PU1WWA	I004C200PU1P	200x50	240	115x100	85x72	20x13		350
PU + Cast Iron Core 铁芯聚氨酯	I004C100CPUWWA	I004C100CPUP	100x50	142	115x100	85x72	20x13		280
	I004C125CPUWWA	I004C125CPUP	125x50	166	115x100	85x72	20x13		300
	I004C150CPUWWA	I004C150CPUP	150x50	195	115x100	85x72	20x13		350
	I004C200CPUWWA	I004C200CPUP	200x50	240	115x100	85x72	20x13		400
PU + Aluminium Core 铝芯聚氨酯	I004C100APUWWA	I004C100APUP	100x50	142	115x100	85x72	20x13		280
	I004C125APUWWA	I004C125APUP	125x50	166	115x100	85x72	20x13		320
	I004C150APUWWA	I004C150APUP	150x50	195	115x100	85x72	20x13		360
	I004C200APUWWA	I004C200APUP	200x50	240	115x100	85x72	20x13		400

Heavy Duty Caster Type D D 款重型脚轮

I004



Housing:

Solid steel welded construction, electrophoresis finished, double ballrace swivel head

Wheel:

Material: Rubber+Steel Core

Bearing type: Precision double ball bearing

支架:

焊接铁支架, 电泳处理
双玻盘

轮子:

材料: 铁芯橡胶

类型: 精密双滚珠轴承

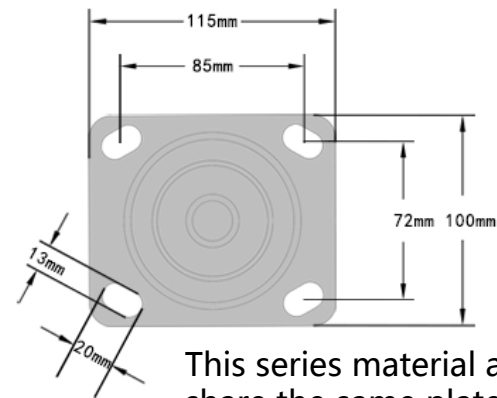

This series material and all size caster share the same plate size.
此系列各种材质和尺寸脚轮的底板尺寸一致。



I004DXXXRWWA



I004DXXXRP



I004DXXXRPF



I004DXXXRPB

Wheel Material	Model Number									
Rubber + Steel Core 铁芯橡胶	I004D100RWWA	I004D100RP	100x50	142	115x100	85x72	20x13		100	
	I004D125RWWA	I004D125RP	125x50	164	115x100	85x72	20x13		120	
	I004D150RWWA	I004D150RP	150x50	190	115x100	85x72	20x13		160	
	I004D200RWWA	I004D200RP	200x50	240	115x100	85x72	20x13		210	

X-1-CAS-STER

Pneumatic Rubber Caster 橡胶充气轮

I004

Housing:
Solid steel welded construction,
zinc plated,
double ballrace swivel head

Wheel:
Material: Rubber + Steel Core
Bearing type: Precision double ball bearing

支架:
双边焊接, 镀锌, 双玻盘
轮子:
材料: 橡胶
轴承类型: 精密双滚珠轴承



Wheel Material	Model Number									
Rubber + Steel Core 铁芯橡胶	I004E200IRWWA	I004E200IRP	200x50	255	115x100	85x72	20x13		120	
	I004E250IRWWA	I004E250IRP	250x50	297	115x100	85x72	20x13		150	
Rubber + Steel Core 铁芯橡胶	I004E200IR1WWA	I004E200IR1P	200x50	255	115x100	85x72	20x13		120	
	I004E250IR1WWA	I004E250IR1P	250x50	297	115x100	85x72	20x13		150	



Electrophoresis finish is available
支架可镀黑



Yellow zinc is available
支架可镀黄锌

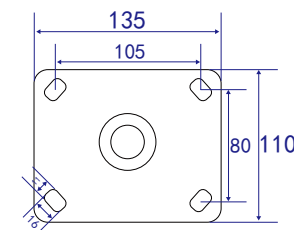

European type plate is available
可选择欧式底板

Y.L.G.A.S.T.E.R

Heavy Duty Kingpinless Caster 重型抗冲击脚轮

I004

**Housing:**

Solid steel bilateral welded construction, kingpinless style, zinc plated

Wheel:

Material: PU

Bearing type: Precision double ball bearing

支架:

双边焊接抗冲击支架

镀锌处理

轮子:

材料: 聚氨酯

类型: 精密双滚珠轴承



I004KXXXCPUP



I004KXXXCPUPF



I004KXXXCPUPB1

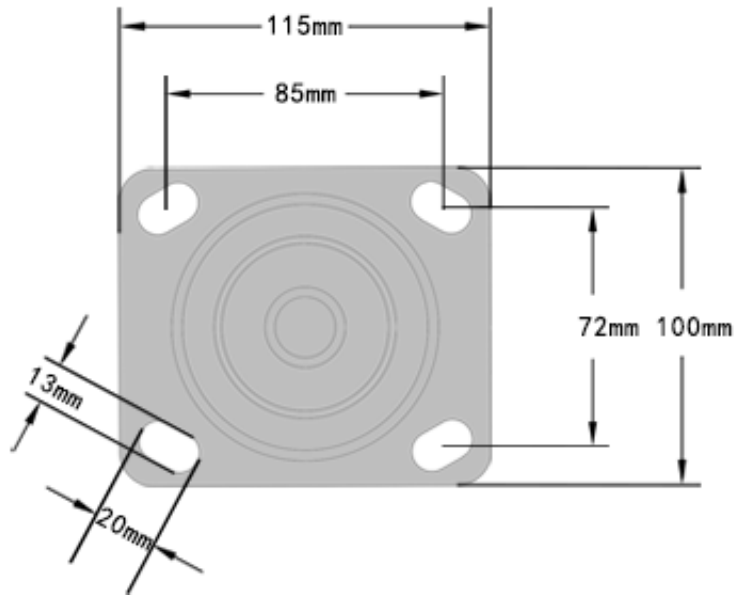

This series all size and fork of caster wheel share the same plate size, bolt hole spacing and bolt hole diameter.

此系列各尺寸和支架脚轮底板和孔距、孔径一致。

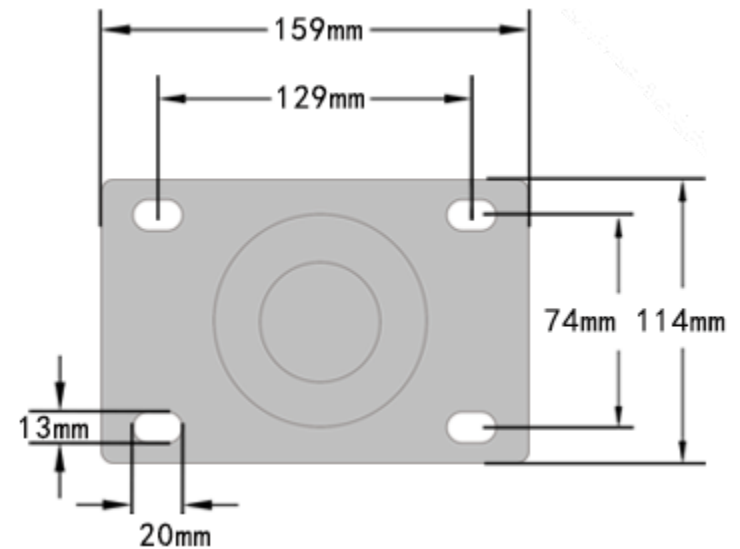
Optional plate size 可选底板尺寸:

YI-CASSTER

Heavy Duty Kingpinless Caster 重型抗冲击脚轮

I004



I004KXXXCPUPB4

I004KXXXCPUPB3

I004KXXXCPUPB1B4

I004KXXXCPUPB3B4



Wheel Material	Model Number								
PU + PP Core 塑芯聚氨酯	I004K100PUP	100x50	150	115x100	85x72	20x13		250	
	I004K125PUP	125x50	175	115x100	85x72	20x13		300	
	I004K150PUP	150x50	200	115x100	85x72	20x13		380	
	I004K200PUP	200x50	250	115x100	85x72	20x13		450	
PU + Cast Iron Core 铁芯聚氨酯	I004K100CPUP	100x50	150	115x100	85x72	20x13		300	
	I004K125CPUP	125x50	175	115x100	85x72	20x13		380	
	I004K150CPUP	150x50	200	115x100	85x72	20x13		450	
	I004K200CPUP	200x50	250	115x100	85x72	20x13		540	
PU + Aluminium Core 铝芯聚氨酯	I004K100APUP	100x50	150	115x100	85x72	20x13		350	
	I004K125APUP	125x50	175	115x100	85x72	20x13		420	
	I004K150APUP	150x50	200	115x100	85x72	20x13		500	
	I004K200APUP	200x50	250	115x100	85x72	20x13		700	

Y-1-GAS-STER

Heavy Duty Caster Type F F 款重型脚轮

1004

**Housing:**

Solid steel welded construction,
blue powder coated

Wheel:

Material: PU/Nylon

Bearing type: Precision double ball bearing

支架:

焊接铁支架

蓝漆

轮子:

材料: 聚氨酯 / 尼龙

类型: 精密双滚珠轴承



Black paint is available

支架可漆黑

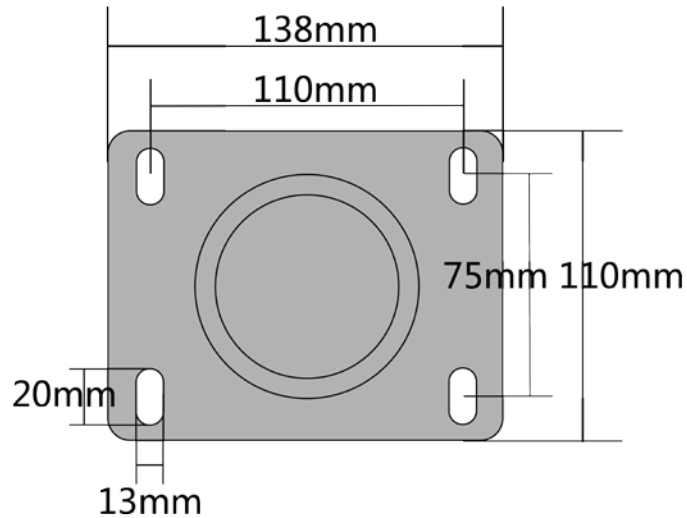

This series all size of swivel/back brake caster wheel share the same plate size, bolt hole spacing and bolt hole diameter.

此系列各尺寸活动、刹车脚轮底板和孔距、孔径一致。

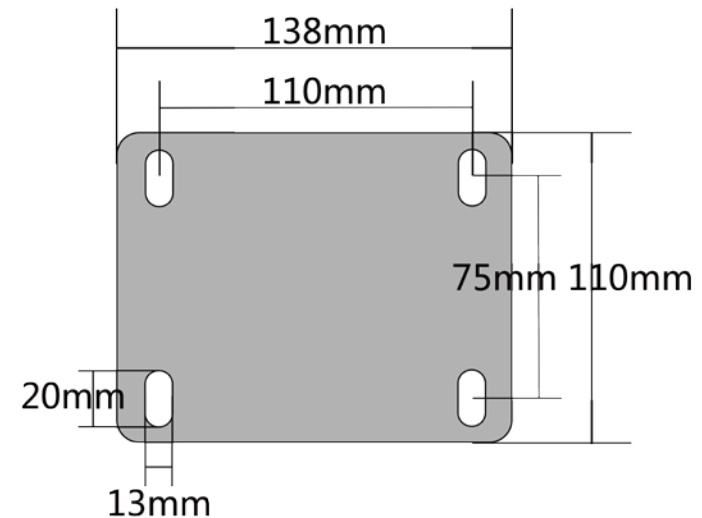

This series all size of fixed caster wheel share the same plate size, bolt hole spacing and bolt hole diameter.

此系列各尺寸固定脚轮底板和孔距、孔径一致。

Y1-CASSTER

Heavy Duty Caster Type F F 款重型脚轮

I004



I004FXXXCPUP



I004FXXXCPUPF



I004FXXXCPUPB3



Wheel Material	Model Number								kg
PU + Cast Iron Core 铁芯聚氨酯	I004F100CPUP	100x50	159	138x110	110x75	20x13		350	
	I004F125CPUP	125x50	177.5	138x110	110x75	20x13		400	
	I004F150CPUP	150x50	205	138x110	110x75	20x13		450	
	I004F200CPUP	200x50	256	138x110	110x75	20x13		700	
MC PA 浇注尼龙	I004F100MPAP	100x50	159	138x110	110x75	20x13		500	
	I004F125MPAP	125x50	177.5	138x110	110x75	20x13		600	
	I004F150MPAP	150x50	205	138x110	110x75	20x13		700	
	I004F200MPAP	200x50	256	138x110	110x75	20x13		1000	

YI-GAS-STER

Super Heavy Duty Caster 超重型脚轮

1005



Housing:

Solid steel bilateral welded construction, black powder coated

Wheel:

Material: Nylon/Steel/PU

Bearing type: Precision double ball bearing

支架:

双边焊接抗冲击支架

黑漆

轮子:

材料: 尼龙 / 锻钢 / 聚氨酯

类型: 精密双滚珠轴承



I005AXXXMPAP



I005AXXXMPAPF



I005AXXXMPAPB5

Load capacity can be customized up to 30 tons 载重可定制达 30 吨

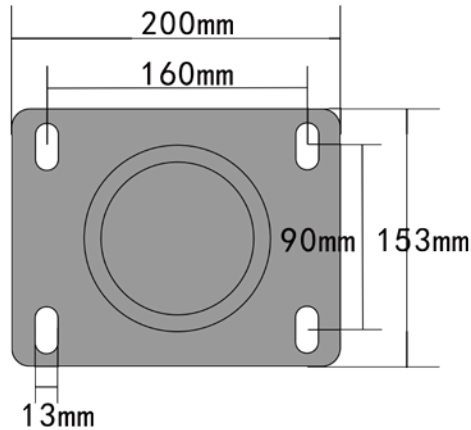

This series all size of swivel/back brake caster wheel share the same plate size, bolt hole spacing and bolt hole diameter.

此系列各尺寸活动、刹车脚轮底板和孔距、孔径一致。

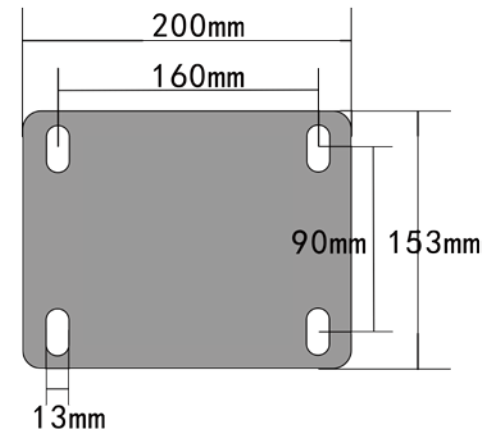

This series all size of swivel/back brake caster wheel share the same plate size, bolt hole spacing and bolt hole diameter.

此系列各尺寸活动、刹车脚轮底板和孔距、孔径一致。

Super Heavy Duty Caster 超重型脚轮

I005



XL-GAS-STER



Wheel Material	Model Number							
MC PA 浇注尼龙	I005A100MPAP	100x75	165	200x153x14	160x90	13		2000
	I005A125MPAP	125x75	185	200x153x14	160x90	13		2000
	I005A150MPAP	150x75	215	200x153x14	160x90	13		2000
	I005A200MPAP	200x75	275	200x153x14	160x90	13		2500
	I005A250MPAP	250x75	320	200x153x14	160x90	13		2500
	I005A300MPAP	300x75	365	200x153x14	160x90	13		3000
Forged Steel 锻钢	I005A100FSP	100x75	165	200x153x14	160x90	13		2000
	I005A125FSP	125x75	185	200x153x14	160x90	13		2000
	I005A150FSP	150x75	215	200x153x14	160x90	13		2500
	I005A200FSP	200x75	275	200x153x14	160x90	13		3000
	I005A250FSP	250x75	320	200x153x14	160x90	13		3000
	I005A300FSP	300x75	365	200x153x14	160x90	13		3000
PU + Cast Iron Core 铁芯聚氨酯	I005A150CPUP	150x75	215	200x153x14	160x90	13		1500
	I005A200CPUP	200x75	275	200x153x14	160x90	13		1500
	I005A250CPUP	250x75	320	200x153x14	160x90	13		1500
	I005A300CPUP	300x75	365	200x153x14	160x90	13		1500

1005



Housing:

Solid steel bilateral welded construction, silver powder coated

Wheel:

Material: Nylon/Steel/PU

Bearing type: Precision double ball bearing

支架:

双边焊接抗冲击支架

银漆

轮子:

材料: 尼龙 / 锻钢 / 聚氨酯

类型: 精密双滚珠轴承



I005AXXXFSPUP-TW



I005AXXXFSPUF-TW

Load capacity can be customized up to 30 tons 载重可定制达 30 吨

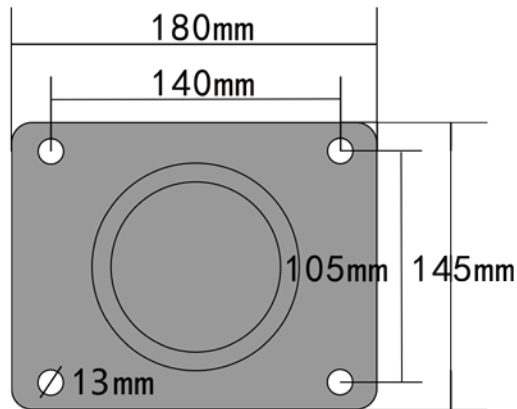

This series all size of swivel/back brake caster wheel share the same plate size, bolt hole spacing and bolt hole diameter.

此系列各尺寸活动、刹车脚轮底板和孔距、孔径一致。

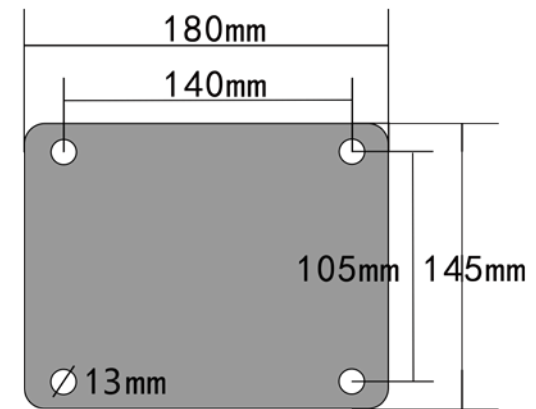

This series all size of swivel/back brake caster wheel share the same plate size, bolt hole spacing and bolt hole diameter.

此系列各尺寸活动、刹车脚轮底板和孔距、孔径一致。

Y-1-CAS-STER

Super Heavy Duty Caster Twin-wheel 超重型双轮脚轮

I005



Wheel Material	Model Number							
MC PA 浇注尼龙	I005A100MPAP-TW	100x50	180	180x145x12	140x105	13		2000
	I005A125MPAP-TW	125x50	195	180x145x12	140x105	13		2500
	I005A150MPAP-TW	150x50	210	180x145x12	140x105	13		2500
	I005A200MPAP-TW	200x50	250	180x145x12	140x105	13		3000
	I005A250MPAP-TW	250x50	330	200x150x12	160x90	13		3000
	I005A300MPAP-TW	300x50	380	200x150x12	160x90	13		3000
Forged Steel 锻钢	I005A100FSP-TW	100x50	180	180x145x12	140x105	13		2000
	I005A125FSP-TW	125x50	195	180x145x12	140x105	13		2500
	I005A150FSP-TW	150x50	210	180x145x12	140x105	13		2500
	I005A200FSP-TW	200x50	250	180x145x12	140x105	13		3000
	I005A250FSP-TW	250x50	330	200x150x12	160x90	13		3000
	I005A300FSP-TW	300x50	380	200x150x12	160x90	13		3000
PU + Cast Iron Core 铁芯聚氨酯	I005A100CPUP-TW	100x50	180	180x145x12	140x105	13		1350
	I005A125CPUP-TW	125x50	195	180x145x12	140x105	13		1350
	I005A150CPUP-TW	150x50	210	180x145x12	140x105	13		1350
	I005A200CPUP-TW	200x50	250	180x145x12	140x105	13		1350
	I005A250CPUP-TW	250x50	330	200x150x12	160x90	13		3000
	I005A300CPUP-TW	300x50	380	200x150x12	160x90	13		3000
PU + Forged Steel Core 钢芯聚氨酯	I005A100FSPUP-TW	100x50	180	180x145x12	140x105	13		1500
	I005A125FSPUP-TW	125x50	195	180x145x12	140x105	13		1500
	I005A150FSPUP-TW	150x50	210	180x145x12	140x105	13		2000
	I005A200FSPUP-TW	200x50	250	180x145x12	140x105	13		2000
	I005A250FSPUP-TW	250x50	330	200x150x12	160x90	13		3000
	I005A300FSPUP-TW	300x50	380	200x150x12	160x90	13		3000



YIGAS-TEER

Standard Industrial Caster 标准工业脚轮

I006

**Housing:**

Made of pressed steel, zinc plated
Double ballrace swivel head

Wheel:

Material: Rubber/PP/Elastic Rubber/Cast Iron/PU

Bearing type: Roller bearing/Double Ball bearing/
Plain bearing

支架:

冲压镀锌铁支架, 双玻盘

轮子:

材料: 橡胶 / 塑料 / 弹力橡胶 / 铸铁 / 聚氨酯

类型: 滚针轴承 / 双滚珠轴承 / 滑动轴承



I006AXXRSW



I006AXXRTP



I006AXXRPF



I006AXXRPB



I006AXXRDR



I006AXXRDB



I006AXXRTR



I006AXXRTRB



I006AXXRSR



I006AXXRSRB

Y1-CAS-STER



YI-GAS-TEER

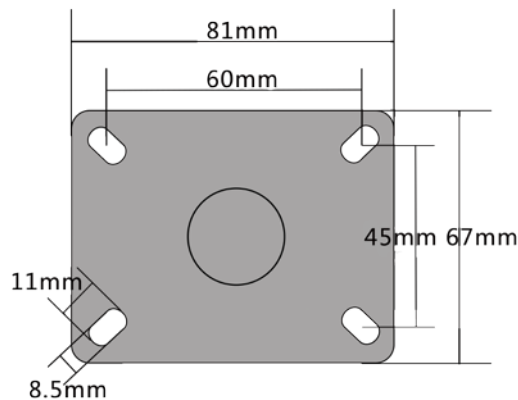

This series 75mm swivel and double brake caster share the same plate size.
此系列各种材质的活动和双刹的 75mm 脚轮底板尺寸一致。

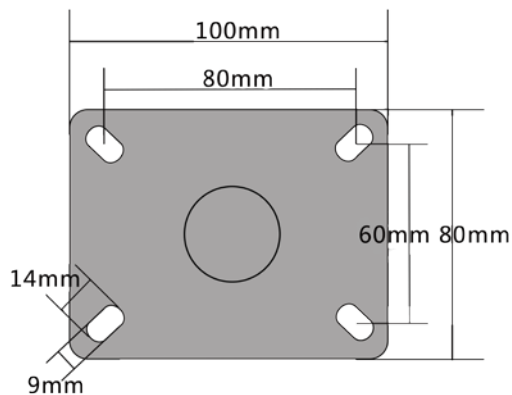

This series 85mm/100mm/125mm swivel and double brake caster share the same plate size.
此系列各种材质的活动和双刹的 85mm/100mm /125mm 脚轮底板尺寸一致。

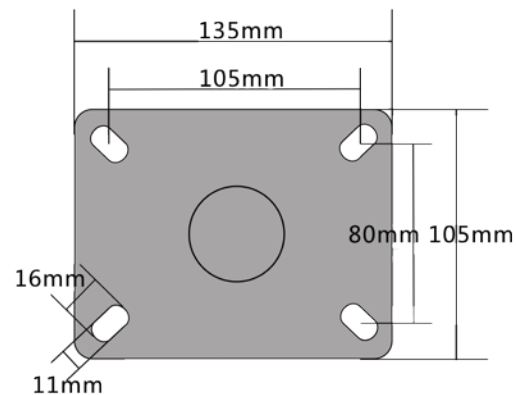

This series 150mm/160mm/200mm/250mm swivel and double brake caster share the same plate size.
此系列各种材质的活动和双刹的 150mm/160mm/200mm/250mm 脚轮底板尺寸一致。

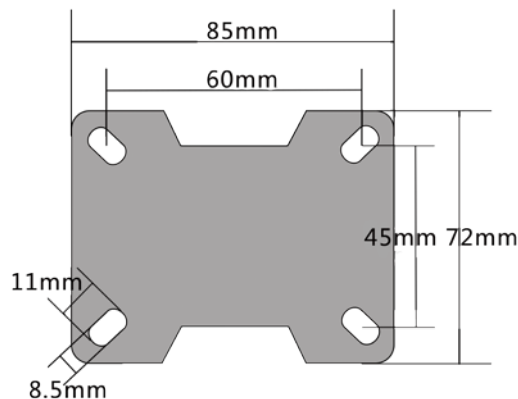

This series 75mm fixed caster share the same plate size.
此系列各种材质的固定的 75mm 脚轮底板尺寸一致。

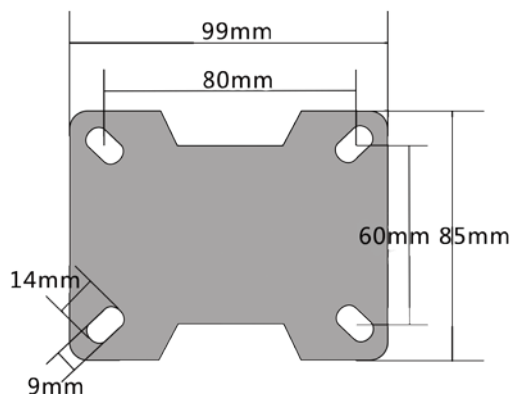

This series 85mm/100mm/125mm fixed caster share the same plate size.
此系列各种材质固定的 85mm/100mm/125mm 脚轮底板尺寸一致。

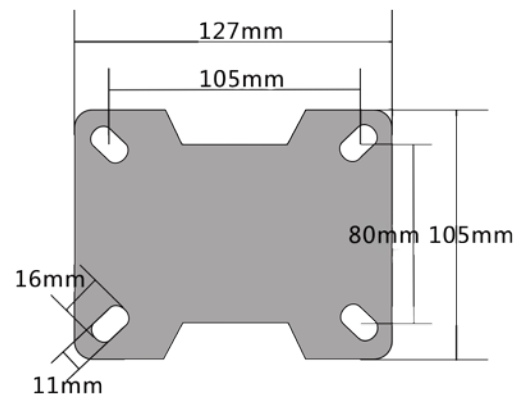

This series 150mm/160mm/200mm/250mm fixed caster share the same plate size.
此系列各种材质的固定的 150mm/160mm/200mm/250mm 脚轮底板尺寸一致。

Standard Industrial Caster 标准工业脚轮

I006



Y1-CAS-TER



Wheel Material	Model Number												
Rubber + Steel Core 铁芯橡胶	I006A075RSW	I006A075RP	75x23	95	81x67	60x45	11x8.5	12.5	12x45	28x40		40	
	I006A085RSW	I006A085RP	85x24	105	100x80	80x60	14x9	12.5	12x45	28x40		50	
	I006A100RSW	I006A100RP	100x27	125	100x80	80x60	14x9	12.5	12x45	28x40		60	
	I006A125RSW	I006A125RP	125x34	151	100x80	80x60	14x9	12.5	12x45	28x40		80	
	I006A160RSW	I006A160RP	160x40	195	135x105	105x80	16x12	16.5	16x40	28x40		100	
	I006A200RSW	I006A200RP	200x46	228	135x105	105x80	16x12	16.5	16x40	28x40		120	
	I006A250RSW	I006A250RP	250x50	285	135x105	105x80	16x12	16.5	16x40	28x40		160	
Rubber + PP Core 塑芯橡胶	I006A075R1SW	I006A075R1P	75x23	97	81x67	60x45	11x8.5	12.5	12x45	28x40		40	
	I006A085R1SW	I006A085R1P	85x24	105	100x80	80x60	14x9	12.5	12x45	28x40		50	
	I006A100R1SW	I006A100R1P	100x27	130	100x80	80x60	14x9	12.5	12x45	28x40		60	
	I006A125R1SW	I006A125R1P	125x34	155	100x80	80x60	14x9	12.5	12x45	28x40		80	
	I006A160R1SW	I006A160R1P	160x40	195	135x105	105x80	16x11	16.5	16x40	28x40		100	
	I006A200R1SW	I006A200R1P	200x46	235	135x105	105x80	16x11	16.5	16x40	28x40		120	
Elastic Rubber + PP Core 塑芯 弹力橡胶	I006A075ERSW	I006A075ERP	75x26	97	81x67	60x45	11x8.5	12.5	12x45	28x40		50	
	I006A085ERSW	I006A085ERP	85x24	105	100x80	80x60	14x9	12.5	12x45	28x40		60	
	I006A100ERSW	I006A100ERP	100x33	130	100x80	80x60	14x9	12.5	12x45	28x40		70	
	I006A125ERSW	I006A125ERP	125x34	155	100x80	80x60	14x9	12.5	12x45	28x40		90	
	I006A160ERSW	I006A160ERP	160x48	195	135x105	105x80	16x11	16.5	16x40	28x40		110	
	I006A200ERSW	I006A200ERP	200x48	235	135x105	105x80	16x11	16.5	16x40	28x40		130	

Standard Industrial Caster 标准工业脚轮

I006



Y1-GAS-STER

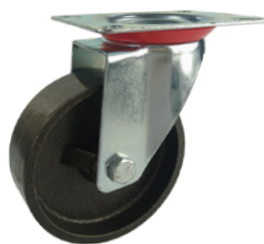

Wheel Material	Model Number												
PP 塑料	I006A075PPSW	I006A075PPP	75x23	97	81x67	60x45	11x8.5	12.5	12x45	28x40		50	
	I006A080PPSW	I006A080PPP	80x22	100	100x80	80x60	14x9	12.5	12x45	28x40		60	
	I006A100PPSW	I006A100PPP	100x27	130	100x80	80x60	14x9	12.5	12x45	28x40		70	
	I006A125PPSW	I006A125PPP	125x34	155	100x80	80x60	14x9	12.5	12x45	28x40		90	
	I006A160PPSW	I006A160PPP	160x40	195	135x105	105x80	16x11	16.5	16x40	28x40		110	
	I006A200PPSW	I006A200PPP	200x46	235	135x105	105x80	16x11	16.5	16x40	28x40		130	
PU + PP Core 塑芯聚氨酯	I006A085PUSW	I006A085PUP	85x22	105	100x80	80x60	14x9	12.5	12x45	28x40		50	
	I006A100PUSW	I006A100PUP	100x27	130	100x80	80x60	14x9	12.5	12x45	28x40		70	
	I006A125PUSW	I006A125PUP	125x34	155	100x80	80x60	14x9	12.5	12x45	28x40		90	
Cast Iron 铸铁	I006A075CSW	I006A075CP	75x22	97	81x67	60x45	11x8.5	12.5	12x45	28x40		50	
	I006A085CSW	I006A085CP	85x22	105	100x80	80x60	14x9	12.5	12x45	28x40		60	
	I006A100CSW	I006A100CP	100x27	130	100x80	80x60	14x9	12.5	12x45	28x40		70	
	I006A125CSW	I006A125CP	125x34	155	100x80	80x60	14x9	12.5	12x45	28x40		90	
	I006A160CSW	I006A160CP	160x39	195	135x105	105x80	16x11	16.5	16x40	28x40		110	
	I006A200CSW	I006A200CP	200x45	235	135x105	105x80	16x11	16.5	16x40	28x40		130	

1007



Housing:

Made of pressed steel, zinc plated double ballrace swivel head

Wheel:

Material: Nylon/PP/Thermoplastic Rubber
Bearing type: Plain bearing

支架:

冲压镀锌铁支架, 双波盘

轮子:

材料: 尼龙 / 塑料 / 热塑性橡胶
类型: 滑动轴承

Y1-CAS-STER

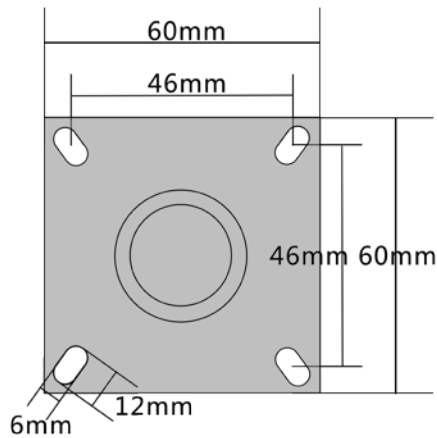

This series all size swivel and double brake caster share the same plate size.

此系列各种材质各个尺寸的活动和双刹脚轮底板尺寸一致。

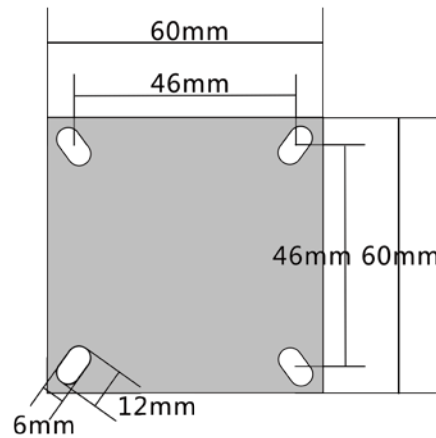

This series 50mm fixed caster share the same plate size.

此系列各种材质的固定的 50mm 脚轮底板尺寸一致。

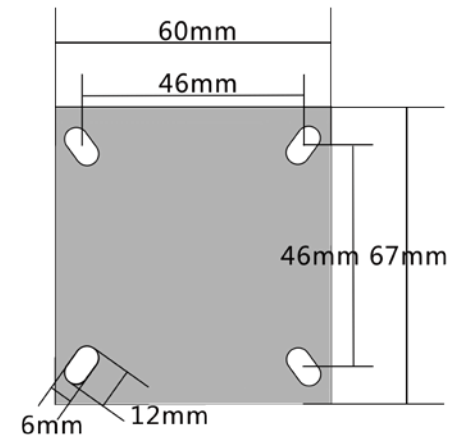

This series 60mm/80mm/100mm fixed caster share the same plate size.

此系列各种材质固定的 60mm/80mm/100mm 脚轮底板尺寸一致。

European Type Light Duty Caster 欧款轻型脚轮

I007



I007LXXXPASW

I007LXXXPAP

I007LXXXPAPF

I007LXXXPAPB2

I007LXXXPAD

I007LXXXPADB2



Wheel Material	Model Number												
PA 尼龙	I007L050PASW	I007L050PAP	50x19	72	60x60	46x46	60x60	46x46	12x6	10.3		38	
	I007L060PASW	I007L060PAP	60x23	82	60x60	46x46	60x67	46x46	12x6	10.3		50	
	I007L080PASW	I007L080PAP	80x24	104	60x60	46x46	60x67	46x46	12x6	10.3		60	
	I007L100PASW	I007L100PAP	100x24	121	60x60	46x46	60x67	46x46	12x6	10.3		70	
PP 塑料	I007L050PPSW	I007L050PPP	50x19	72	60x60	46x46	60x60	46x46	12x6	10.3		38	
	I007L060PPSW	I007L060PPP	60x23	82	60x60	46x46	60x67	46x46	12x6	10.3		50	
	I007L080PPSW	I007L080PPP	80x24	104	60x60	46x46	60x67	46x46	12x6	10.3		60	
	I007L100PPSW	I007L100PPP	100x24	121	60x60	46x46	60x67	46x46	12x6	10.3		70	
TPR + PP Core 塑芯 热塑橡胶	I007L050TPRSW	I007L050TPRP	50x19	72	60x60	46x46	60x60	46x46	12x6	10.3		38	
	I007L060TPRSW	I007L060TPRP	60x23	82	60x60	46x46	60x67	46x46	12x6	10.3		50	
	I007L080TPRSW	I007L080TPRP	80x24	104	60x60	46x46	60x67	46x46	12x6	10.3		60	
	I007L100TPRSW	I007L100TPRP	100x24	121	60x60	46x46	60x67	46x46	12x6	10.3		70	

XLGASSTER

1007



Housing:

Made of pressed steel, zinc plated double ballrace swivel head,

Wheel:

Material: Thermoplastic Rubber/Hard Rubber/PP
Bearing type: No bearing

支架:

冲压镀锌铁支架, 双波盘

轮子:

材料: 热塑性橡胶 / 硬橡胶 / 塑料
类型: 无轴承

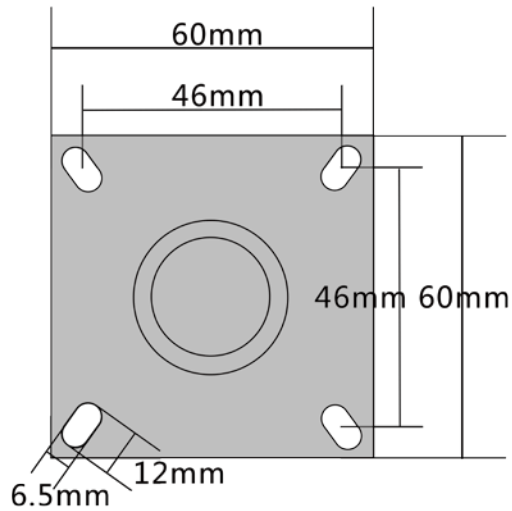

This series 50mm swivel and double brake caster share the same plate size.

此系列各种材质 50mm 的活动和双刹脚轮底板尺寸一致。

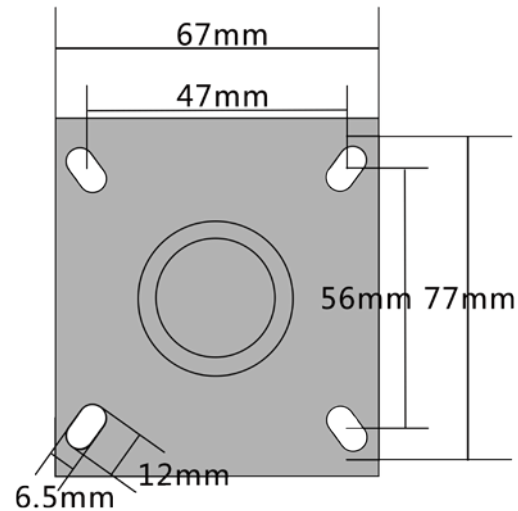

This series 75mm swivel and double brake caster share the same plate size.

此系列各种材质 75mm 的活动和双刹脚轮底板尺寸一致。

Y1-CAS-STER

European Type Light Duty Caster Twin-wheel 欧款轻型双轮脚轮

I007



I007LXXXTPRP-TW

I007LXXXTPRPB2-TW

I007LXXXTPRD-TW

I007LXXXTPRDB2-TW



Wheel Material	Model Number										
TPR + PP Core 塑芯 热塑橡胶	I007L050TPRP-TW	50x19	8x22	71.5	60x60	46x46	12x6.5	10	/	60	
	I007L075TPRP-TW	75x23	8x28	103	77x67	56x47	12x6.5	12	/	80	
Hard Rubber 硬橡胶	I007L050HRP-TW	50x20	6x23	71.5	60x60	46x46	12x6.5	10	/	70	
PP 塑料	I007L050PPP-TW	50x20	6x22.5	71.5	60x60	46x46	12x6.5	10	/	70	

YI-CAS-STER

European Type Medium Duty Caster 欧款中型脚轮

I007



Housing:

Made of pressed steel, zinc plated, double ballrace swivel head

Wheel:

Material: Nylon/PP/PU/Rubber/Elastic Rubber

Hardness: 90±5 Shore A

Bearing type: Roller bearing/Precision double ball bearing/Plain bearing

Temperature range: -20°C ~80°C

支架:

冲压镀锌铁支架, 双玻盘

轮子:

材料: 尼龙 / 塑料 / 聚氨酯 / 橡胶 / 弹力橡胶

轮子表面硬度: 90±5 Shore A

轴承类型: 滚针轴承 / 精密双滚珠轴承 / 滑动轴承

温度范围: -20°C ~80°C

Y1-CAS-TER



Model Number								
I007M080RPASW	I007M080BPASW	I007M080PPASW	80x30	12x41	15x37	8x41	100	
I007M100RPASW	I007M100BPASW	I007M100PPASW	100x30	12x41	15x37	8x41	120	
I007M125SRPASW	I007M125SBPASW	I007M125SPPASW	125x30	12x41	15x37	10x41	150	
I007M125MRPASW	I007M125MBPASW	I007M125MPPASW	125x40	15x51	15x47	10x51	150	
I007M160RPASW	I007M160BPASW	I007M160PPASW	160x45	20x61	17x57	12x61	300	
I007M200RPASW	I007M200BPASW	I007M200PPASW	200x50	20x61	17x57	12x61	350	
I007M080RPPSW	I007M080BPPSW	I007M080PPPSW	80x30	12x41	15x37	8x41	100	
I007M100RPPSW	I007M100BPPSW	I007M100PPPSW	100x30	12x41	15x37	8x41	120	
I007M125SRPPSW	I007M125SBPPSW	I007M125SPPPSW	125x30	12x41	15x37	10x41	150	
I007M125MRPPSW	I007M125MBPPSW	I007M125MPPPSW	125x40	15x51	15x47	10x51	150	
I007M160RPPSW	I007M160BPPSW	I007M160PPPSW	160x45	20x61	17x57	12x61	300	
I007M200RPPSW	I007M200BPPSW	I007M200PPPSW	200x50	20x61	17x57	12x61	350	

European Type Medium Duty Caster 欧款中型脚轮

I007



Y-L-GAS-TEER

Model Number								
								kg
I007M080RPUSW	I007M080BPUSW	I007M080PPUSW	80x30		12x41	15x37	8x41	100
I007M100RPUSW	I007M100BPUSW	I007M100PPUSW	100x30		12x41	15x37	8x41	120
I007M125SRPUSW	I007M125SBPUSW	I007M125SPPUSW	125x30		12x41	15x37	10x41	150
I007M125MRPUSW	I007M125MBPUSW	I007M125MPPUSW	125x40		15x51	15x47	10x51	150
I007M160RPUSW	I007M160BPUSW	I007M160PPUSW	160x45		20x61	17x47	12x61	300
I007M200RPUSW	I007M200BPUSW	I007M200PPUSW	200x50		20x61	17x47	12x61	350
I007M080RRSW	/	/	80x27		/	12x40	/	60
I007M100RRSW	/	/	100x30		/	12x40	/	80
I007M125SRRSW	/	/	125x38		/	12x40	/	100
I007M125MRRSW	/	/	125x38		/	15x50	/	100
I007M160RRSW	/	/	160x50		/	20x60	/	150
I007M200RRSW	/	/	200x50		/	20x60	/	200
I007M080RR1SW	/	/	80x27		/	12x40	/	60
I007M100RR1SW	/	/	100x30		/	12x40	/	80
I007M125SRR1SW	/	/	125x38		/	12x40	/	100
I007M125MRR1SW	/	/	125x38		/	15x50	/	100
I007M160RR1SW	/	/	160x50		/	20x60	/	150
I007M200RR1SW	/	/	200x50		/	20x60	/	200
I007M080RERSW	/	/	80x36	/	12x41	12x40	/	100
I007M100RERSW	/	/	100x36	/	12x41	12x40	/	150
I007M125SRERSW	/	/	125x36	/	12x41	12x40	/	200
I007M125MRERSW	I007M125MBERSW	/	125x36	125x36	15x51	15x50	15x44	200
I007M160RERSW	I007M160BERSW	/	160x45	150x50	20x61	20x60	20x60	350
I007M200RERSW	I007M200BERSW	/	200x50	200x50	20x61	20x60	20x60	400



I007



Y-CASTER



I007MXXXXPPP



I007MXXXXPPPF



I007MXXXXPPPB



I007MXXXXPPD

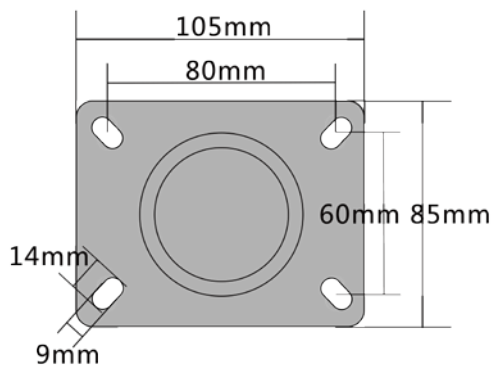

This series 80mm/100mm/125mm swivel and double brake caster share the same plate size.

此系列各种材质 80mm/100mm/125mm 小底板的活动和双刹脚轮底板尺寸一致。

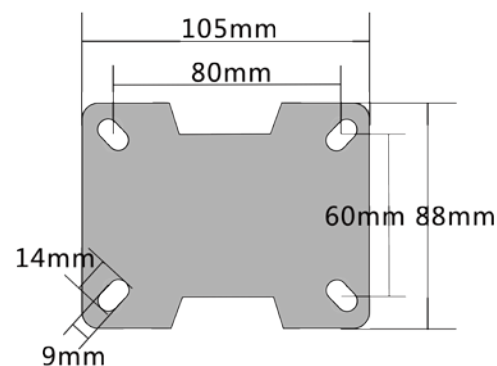

This series 80mm/100mm/125mm fixed caster share the same plate size.

此系列各种材质 80mm/100mm/125mm 小底板的固定脚轮底板尺寸一致。



I007MXXXXPPDB



I007MXXXXPPT



I007MTXXXXPPTB

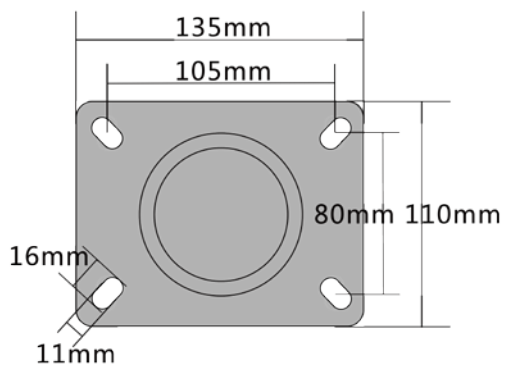

This series 125mm m /150mm /200mm swivel and double brake caster share the same plate size.

此系列各种材质 125mm 中底板 /150mm /200mm 的活动和双刹脚轮底板尺寸一致。

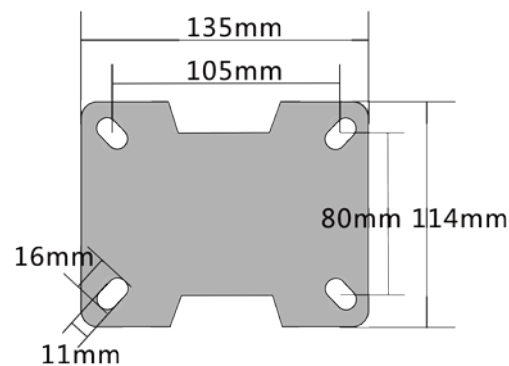

This series 125mm m /150mm /200mm fixed caster share the same plate size.

此系列各种材质 125mm 中底板 /150mm /200mm 的固定脚轮底板尺寸一致。

European Type Medium Duty Caster 欧款中型脚轮

1007



Y1-CAS-STER



Wheel Material	Model Number								
PA 尼龙	I007M080PAP	80x30	108	105x85	80x60	14x9	12.5	12x25	100
	I007M100PAP	100x30	128	105x85	80x60	14x9	12.5	12x25	120
	I007M125SPAP	125x30	155	105x85	80x60	14x9	12.5	12x25	150
	I007M125MPAP	125x40	156	135x110	105x80	16x11	12.5	12x25	150
	I007M160PAP	160x45	195	135x110	105x80	16x11	16.5	16x40	300
	I007M200PAP	200x50	240	135x110	105x80	16x11	16.5	16x40	350
PP 塑料	I007M080PPP	80x30	108	105x85	80x60	14x9	12.5	12x25	100
	I007M100PPP	100x30	128	105x85	80x60	14x9	12.5	12x25	120
	I007M125SPPP	125x30	155	105x85	80x60	14x9	12.5	12x25	150
	I007M125MPPP	125x40	156	135x110	105x80	16x11	12.5	12x25	150
	I007M160PPP	160x45	195	135x110	105x80	16x11	16.5	16x40	300
	I007M200PPP	200x50	240	135x110	105x80	16x11	16.5	16x40	350
PU + Nylon Core 尼龙芯聚氨酯	I007M080PUP	80x30	108	105x85	80x60	14x9	12.5	12x25	100
	I007M100PUP	100x30	128	105x85	80x60	14x9	12.5	12x25	120
	I007M125SPUP	125x30	155	105x85	80x60	14x9	12.5	12x25	150
	I007M125MPUP	125x40	156	135x110	105x80	16x11	12.5	12x25	150
	I007M160PUP	160x45	195	135x110	105x80	16x11	16.5	16x40	300
	I007M200PUP	200x50	240	135x110	105x80	16x11	16.5	16x40	350

European Type Medium Duty Caster 欧款中型脚轮

I007



Y-L-GAS-STER



Wheel Material	Model Number								
Black Rubber + Steel Core 铁芯黑色橡胶	I007M080RP	80x27	108	105x85	80x60	14x9	12.5	12x25	60
	I007M100RP	100x30	128	105x85	80x60	14x9	12.5	12x25	80
	I007M125SRP	125x38	155	105x85	80x60	14x9	12.5	12x25	100
	I007M125MRP	125x38	156	135x110	105x80	16x11	12.5	12x25	100
	I007M160RP	160x50	195	135x110	105x80	16x11	16.5	16x40	150
	I007M200RP	200x50	240	135x110	105x80	16x11	16.5	16x40	200
Gray Rubber + Steel Core 铁芯灰色橡胶	I007M080R1P	80x27	108	105x85	80x60	14x9	12.5	12x25	60
	I007M100R1P	100x30	128	105x85	80x60	14x9	12.5	12x25	80
	I007M125SR1P	125x38	155	105x85	80x60	14x9	12.5	12x25	100
	I007M125MR1P	125x38	156	135x110	105x80	16x11	12.5	12x25	100
	I007M160R1P	160x50	195	135x110	105x80	16x11	16.5	16x40	150
	I007M200R1P	200x50	240	135x110	105x80	16x11	16.5	16x40	200
Elastic Rubber + PP core 塑芯弹力橡胶	I007M080ERP	80x35	108	105x85	80x60	14x9	12.5	12x25	100
	I007M100ERP	100x36	128	105x85	80x60	14x9	12.5	12x25	150
	I007M125SERP	125x36	155	105x85	80x60	14x9	12.5	12x25	200
	I007M125MERP	125x36	156	135x110	105x80	16x11	12.5	12x25	200
	I007M160ERP	160x45	195	135x110	105x80	16x11	16.5	16x40	350
	I007M200ERP	200x50	240	135x110	105x80	16x11	16.5	16x40	400

1007



Housing:

Made of pressed steel, zinc plated double ballrace swivel head

Wheel:

Material: Nylon/PU/Elastic rubber

Bearing type: Precision double ball bearing

支架:

冲压镀锌铁支架, 双波盘

轮子:

材料: 尼龙 / 聚氨酯 / 弹力橡胶

类型: 精密双滚珠轴承



I007HXXXPASW



I007HXXXPAP



I007HXXXPAPF



I007HXXXPAPB

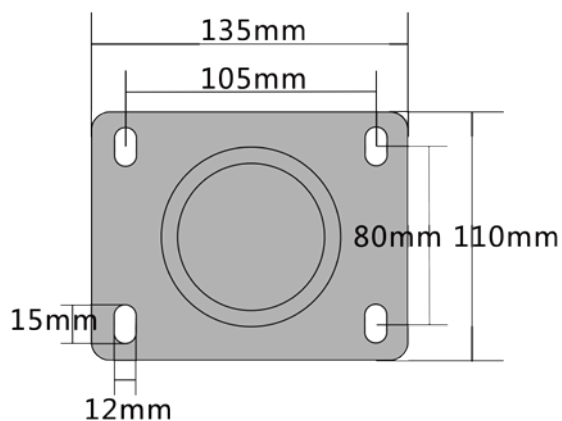

Optional wheels 匹配脚轮:



Nylon
尼龙轮子



Cast iron core PU
铁芯圆弧聚氨酯轮子

This series all size caster share the same plate size.
各种材质和尺寸脚轮底板尺寸一致。

X1-CASSTER

European Type Heavy Duty Caster 欧款重型脚轮

I007



Wheel Material	Model Number										kg
PA 尼龙	I007H100PASW	I007H100PAP	100x50	20x55	142	135x110	105x80	15x12		300	
	I007H125PASW	I007H125PAP	125x50	20x55	164	135x110	105x80	15x12		400	
	I007H150PASW	I007H150PAP	150x50	20x55	194	135x110	105x80	15x12		500	
	I007H200PASW	I007H200PAP	200x50	20x55	239	135x110	105x80	15x12		550	
PU + PP Core 塑芯聚氨酯	I007H125PUSW	I007H125PUP	125x45	17x62	156	135x110	105x80	15x12		330	
	I007H150PUSW	I007H150PUP	150x45	17x62	190	135x110	105x80	15x12		380	
	I007H200PUSW	I007H200PUP	200x45	17x62	240	135x110	105x80	15x12		410	
PU + Cast Iron Core 铁芯聚氨酯	I007H100CPUSW	I007H100CPUP	100x50	17x56	142	135x110	105x80	15x12		300	
	I007H125CPUSW	I007H125CPUP	125x50	17x56	164	135x110	105x80	15x12		350	
	I007H150CPUSW	I007H150CPUP	150x50	17x56	194	135x110	105x80	15x12		400	
	I007H200CPUSW	I007H200CPUP	200x50	17x56	239	135x110	105x80	15x12		450	
	I007H250CPUSW	I007H250CPUP	250x50	25x56	292	135x110	105x80	15x12		500	
PU + Aluminium Core 铝芯聚氨酯	I007H100APUSW	I007H100APUP	100x50	20x60	142	135x110	105x80	15x12		300	
	I007H125APUSW	I007H125APUP	125x50	20x60	164	135x110	105x80	15x12		350	
	I007H150APUSW	I007H150APUP	150x50	20x60	194	135x110	105x80	15x12		400	
	I007H200APUSW	I007H200APUP	200x50	20x60	239	135x110	105x80	15x12		500	
	I007H250APUSW	I007H250APUP	250x50	20x60	292	135x110	105x80	15x12		600	
Elastic Rubber + Aluminium Core 铝芯弹力 橡胶	I007H125ARSW	I007H125ARP	125x50	20x60	164	135x110	105x80	15x12		200	
	I007H150ARSW	I007H150ARP	150x50	20x60	194	135x110	105x80	15x12		250	
	I007H200ARSW	I007H200ARP	200x50	20x60	239	135x110	105x80	15x12		300	
	I007H250ARSW	I007H250ARP	250x50	20x60	292	135x110	105x80	15x12		350	



YI-GAS-STER

Stainless Steel Light Duty Caster 不锈钢轻型脚轮

1008



Housing:

Stainless steel pressed, double ballrace swivel head

Wheel:

Material: PC/TPR/PU

Bearing type: Plain bearing/Precision single ball bearing

支架:

冲压不锈钢支架, 双玻盘

轮子:

材料: 塑料 / 热塑性橡胶 / 聚氨酯

轴承类型: 滑动轴承 / 精密单滚珠轴承



I008LXXXPAP



I008LXXXPAPF



I008LXXXPAPB

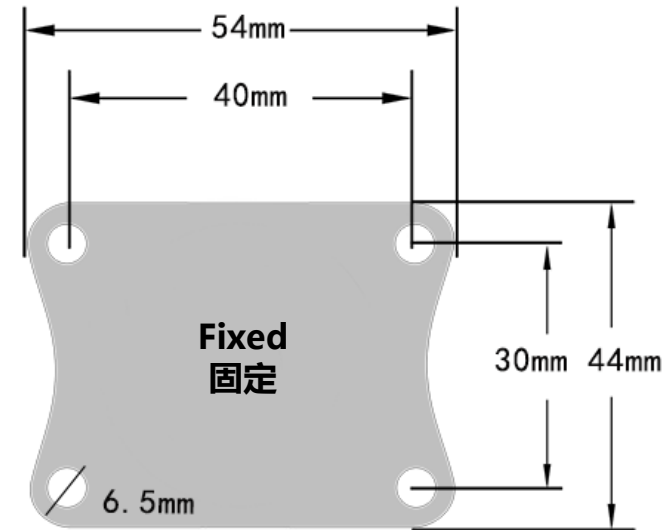
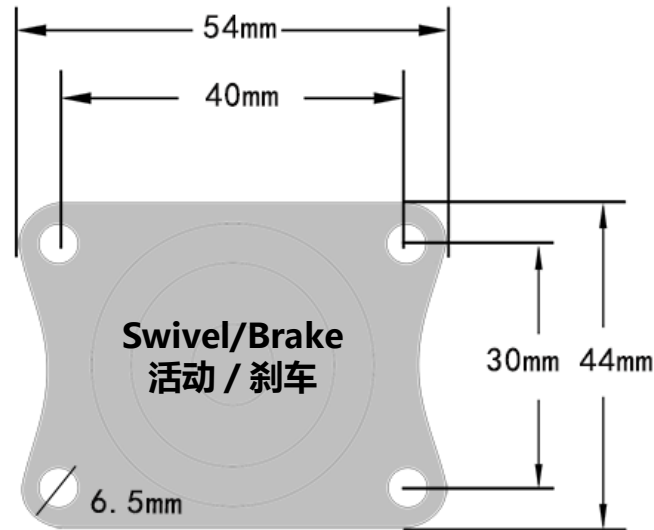

This series all size caster share the same plate size.
此系列各种材质和尺寸脚轮底板尺寸一致。

Stainless Steel Light Duty Caster 不锈钢轻型脚轮

I008



I008LXXXPAT



I008LXXXPATB



Model Number									
I008L040PAP	40x20	60	54x44	40x30	6.5	10x25			30
I008L050PAP	50x22	70	54x44	40x30	6.5	10x25			50
I008L040PCP	40x20	60	54x44	40x30	6.5	10x25			30
I008L050PCP	50x22	70	54x44	40x30	6.5	10x25			50
I008L040TPRP	40x20	60	54x44	40x30	6.5	10x25			30
I008L050TPRP	50x22	70	54x44	40x30	6.5	10x25			50
I008L040PUP	40x20	60	54x44	40x30	6.5	10x25			30
I008L050PUP	50x22	70	54x44	40x30	6.5	10x25			50

YI-GAS-STER

Stainless Steel Medium Duty Caster 不锈钢中型脚轮

1008



Housing:

Stainless steel pressed, double ballrace swivel head

Wheel:

Material: Nylon/PU/TPR

Bearing type: Plain bearing/Precision single ball bearing

支架:

冲压不锈钢支架, 双玻盘

轮子:

材料: 尼龙 / 聚氨酯 / 热塑性橡胶

轴承类型: 滑动轴承 / 精密单滚珠轴承



I008MXXXPAP



I008MXXXPAPF

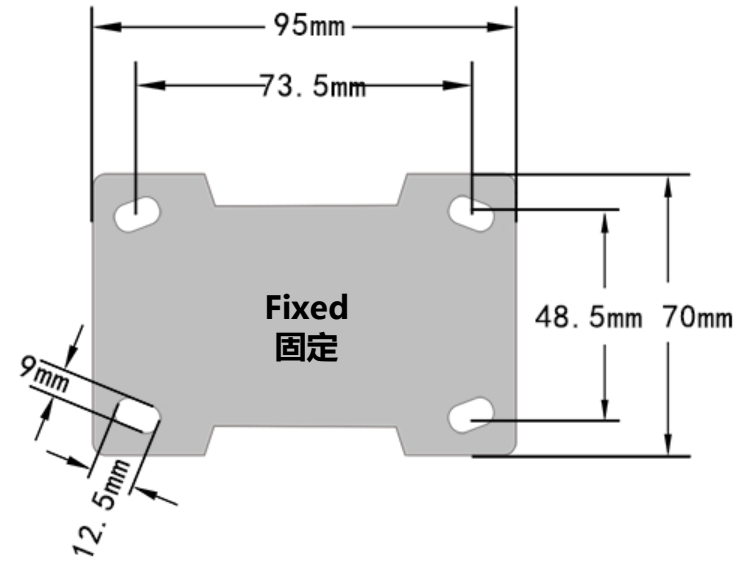
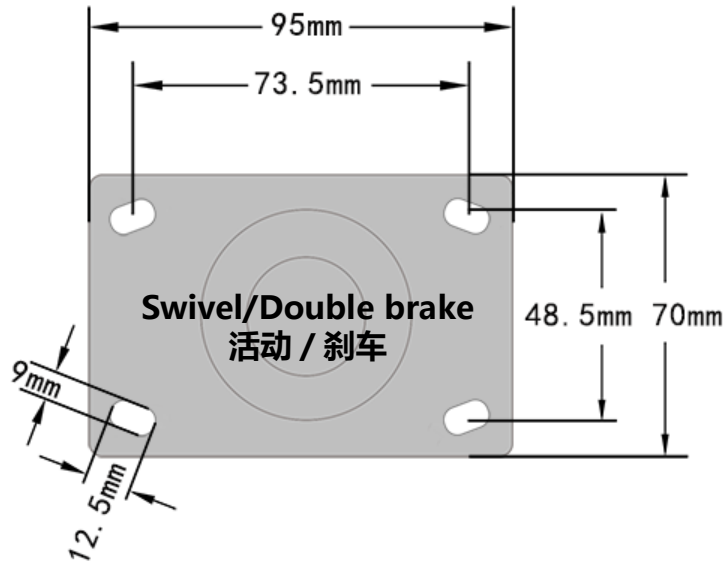

This series all size caster share the same plate size.
此系列各种材质和尺寸脚轮底板尺寸一致。

Stainless Steel Medium Duty Caster 不锈钢中型脚轮

I008



I008MXXXPAPB2



I008MXXXPAD



I008MXXXPADB2



Model Number								
I008M075PAP	75x32	113	95X70	73.5x48.5	12.5x9	12.5		80
I008M100PAP	100x32	137	95X70	73.5x48.5	12.5x9	12.5		110
I008M125PAP	125x32	164	95X70	73.5x48.5	12.5x9	12.5		130
I008M075PUP	75x32	113	95X70	73.5x48.5	12.5x9	12.5		80
I008M100PUP	100x32	137	95X70	73.5x48.5	12.5x9	12.5		110
I008M125PUP	125x32	164	95X70	73.5x48.5	12.5x9	12.5		130
I008M075TPRP	75x32	113	95X70	73.5x48.5	12.5x9	12.5		80
I008M100TPRP	100x32	137	95X70	73.5x48.5	12.5x9	12.5		110
I008M125TPRP	125x32	164	95X70	73.5x48.5	12.5x9	12.5		130

YIGAS-STER

I008



Housing:

Stainless steel welded construction, double ballrace swivel head

Wheel:

Material: PA/PU/TPR

Bearing type: Precision double ball bearing

支架:

不锈钢焊接支架, 双玻盘

轮子:

材料: 尼龙 / 聚氨酯 / 热塑性橡胶

轴承类型: 精密双滚珠轴承



I008HXXXPAP



I008HXXXPAPF



I008HXXXPAPB

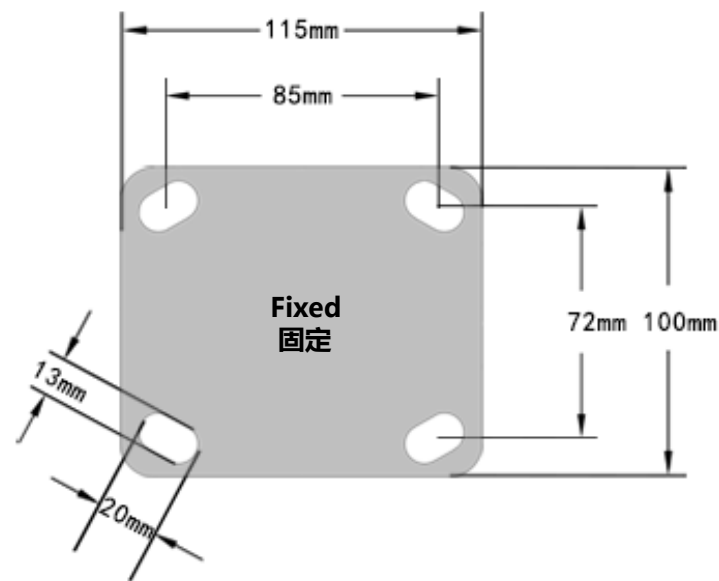
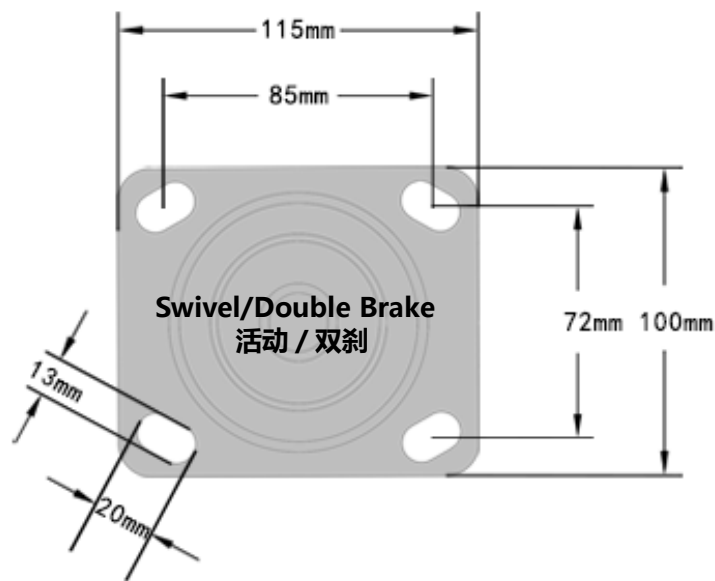

Y1-CAS-STER

Stainless Steel Heavy Duty Caster 不锈钢重型脚轮

I008



Wheel Material	Model Number							
PA 尼龙	I008H100PAP	100x50	143	115x100	85x72	20x13		250
	I008H125PAP	125x50	165	115x100	85x72	20x13		300
	I008H150PAP	150x50	191	115x100	85x72	20x13		350
	I008H200PAP	200x50	241	115x100	85x72	20x13		400
PU+PP Core 塑芯聚氨酯	I008H100PUP	100x50	143	115x100	85x72	20x13		250
	I008H125PUP	125x50	165	115x100	85x72	20x13		280
	I008H150PUP	150x50	191	115x100	85x72	20x13		300
	I008H200PUP	200x50	241	115x100	85x72	20x13		350
TPR + PP Core 塑芯 热塑橡胶	I008H100TPRP	100x50	143	115x100	85x72	20x13		200
	I008H125TPRP	125x50	165	115x100	85x72	20x13		230
	I008H150TPRP	150x50	191	115x100	85x72	20x13		280
	I008H200TPRP	200x50	241	115x100	85x72	20x13		300
PU+ Aluminium Core 铝芯聚氨酯	I008H100APUP	100x50	143	115x100	85x72	20x13		250
	I008H125APUP	125x50	165	115x100	85x72	20x13		300
	I008H150APUP	150x50	192	115x100	85x72	20x13		350
	I008H200APUP	200x50	242	115x100	85x72	20x13		400



Y1-GAS-STER

Low Profile Caster Type A A 款低重心脚轮

1009



Housing:

Made of pressed steel,
electrophoresis finish,
double ballrace swivel head

Wheel:

Material: Nylon/PP
Bearing type: No bearing (40/50mm)
Precision double ball bearing (65/75mm)

支架:

冲压电泳铁支架, 双玻盘

轮子:

材料: 尼龙 / 塑料
轴承类型: 无轴 (40/50mm)
精密双滚珠轴承 (65/75mm)



I009AXXPAP



I009AXXPAPF



I009AXXPAPB1



I009AXXPAPB2

Model Number				Wheel Dia	Housing Dia	Wheel Dia	Housing Dia	Housing Dia	Housing Dia	Housing Dia	Weight (kg)
Icon 1	Icon 2	Icon 3	Icon 4								
I009A040PAP	I009A040PAPF	I009A040PAPB1	/	40x27.5	58	66x48	48x32	8x6	/	70	
I009A050PAP	I009A050PAPF	I009A050PAPB1	/	50x30.5	68	72x54	54x36	9x7	/	100	
I009A065PAP	I009A065PAPF	/	I009A065PAPB2	65x38.5	92	95x69	72x43	12x9	☒☒	200	
I009A075PAP	I009A075PAPF	/	I009A075PAPB2	75x45	105	105x80	82x60	11x9	☒☒	300	

X-L-CAS-STER

Low Profile Caster A/B A/B 款低重心脚轮

I009



Housing:

Made of pressed steel, electrophoresis finish, double ballrace swivel head

Wheel:

Material: Nylon
Bearing type: Plain bearing
Style: Twin-wheel

支架:

冲压电泳铁支架, 双玻盘

轮子:

材料: 尼龙
轴承类型: 滑动轴承
类型: 双轮



I009AXXXPAP-TW



I009AXXXPAPF-TW

Model Number										
I009A040PAP-TW	I009A040PAPF-TW			40x24	61	95x66	72x45	8.5		150
I009A050PAP-TW	I009A050PAPF-TW			50x24	72	95x66	72x45	8.5		180
I009A065PAP-TW	I009A065PAPF-TW			65x24	85	95x66	72x45	8.5		200
I009A075PAP-TW	I009A075PAPF-TW			75x24	99	95x66	72x45	8.5		250

Housing:

Solid steel welded construction, electrophoresis finish, double ballrace swivel head

Wheel:

Material: PU+Cast Iron Core
Bearing type: Precision double ball bearing

支架:

冲压电泳铁支架, 双玻盘

轮子:

材料: 聚氨酯 + 铁芯
轴承类型: 精密双滚珠轴承



I009BXXCPUP



I009BXXCPUPF



I009BXXCPUPB

Model Number											
I009B075CPUP	I009B075CPUPF	I009B075CPUPB			75x50	113	115x100	85x72	20x13		500

YI-GAS-TER

Low Profile Caster Type C C款低重心脚轮

I009



Housing:

Made of pressed steel, zinc plated, single ballrace swivel head

Wheel:

Material: PP/Nylon/Hard Rubber/Cast Iron
Bearing type: Plain bearing

支架:

冲压镀锌铁支架, 单玻盘

轮子:

材料: 塑料 / 尼龙 / 硬橡胶 / 铸铁
轴承类型: 滑动轴承

X-1-CAS-STER

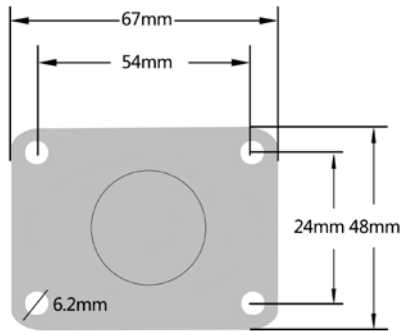

I009C050XXP /B1

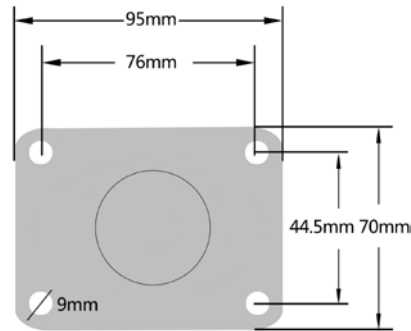

I009C065XXP /B1

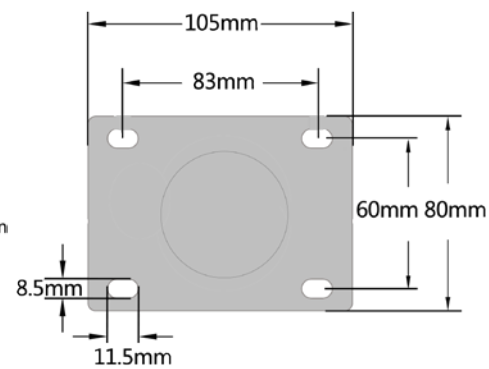

I009C075XXP /B1

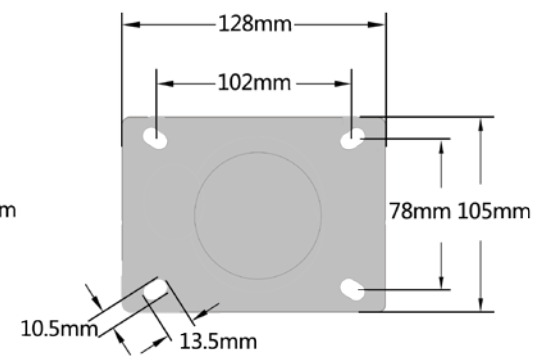

I009C100XXP /B1

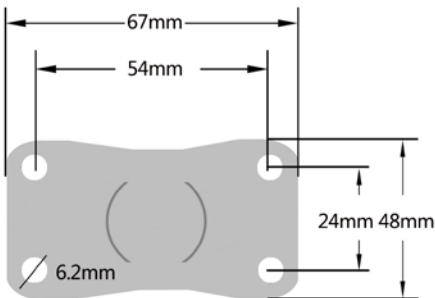

I009C050XXPF

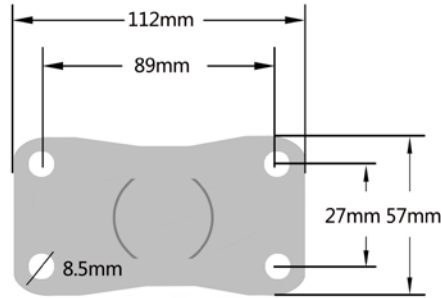

I009C065XXPF

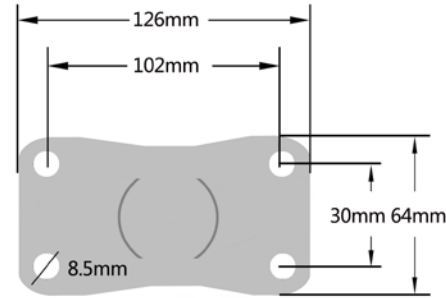

I009C075XXPF

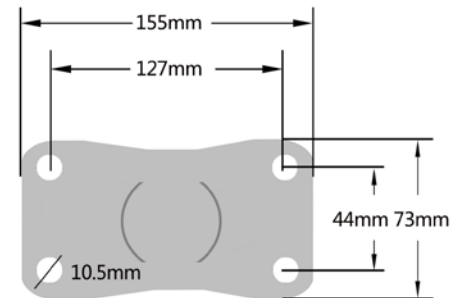

I009C100XXPF

Low Profile Caster Type C C 款低重心脚轮

I009



I009CXXXHRP



I009CXXXHRPF



I009CXXXHRPB1



Wheel Material	Model Number											
PP 塑料	I009C050PPSW	I009C050PPP	50x20	63	67x48	54x24	6.2	67x48	54x24	6.2	/	70
	I009C065PPSW	I009C065PPP	63x22	84	95x70	76x44.5	9	112x57	89x27	8.5	/	75
	I009C075PPSW	I009C075PPP	75x31	93	105x77	85x60	11.5x8.5	126x64	102x30	8.5	/	80
	I009C100PPSW	I009C100PPP	100x32	129	128x105	102x78	13.5x10.5	155x73	127x44	10.5	/	100
PA 尼龙	I009C050PASW	I009C050PAP	50x20	63	67x48	54x24	6.2	67x48	54x24	6.2	/	75
	I009C065PASW	I009C065PAP	63x22	84	95x70	76x44.5	9	112x57	89x27	8.5	/	80
	I009C075PASW	I009C075PAP	75x27	98	105x77	85x60	11.5x8.5	126x64	102x30	8.5	/	85
	I009C100PASW	I009C100PAP	100x32	129	128x105	102x78	13.5x10.5	155x73	127x44	10.5	/	100
Hard Rubber 硬橡胶	I009C050HRSW	I009C050HRP	50x23	63	67x48	54x24	6.2	67x48	54x24	6.2	/	40
	I009C065HRSW	I009C065HRP	64x27	84	95x70	76x44.5	9	112x57	89x27	8.5	/	50
	I009C075HRSW	I009C075HRP	75x30	98	105x77	85x60	11.5x8.5	126x64	102x30	8.5	/	60
	I009C100HRSW	I009C100HRP	100x39	129	128x105	102x78	13.5x10.5	155x73	127x44	10.5	/	80

YILGASSTER

Scaffolding Caster Type A A 款脚手架脚轮

I010



Housing:

Solid steel welded construction, zinc plated, double ballrace swivel head

Wheel:

Material: PP/PVC/PU/Rubber

Bearing type: Precision double ball bearing / Roller Bearing

支架:

焊接镀锌铁支架, 双玻盘

轮子:

材料: 塑料 / 聚氯乙烯 / 聚氨酯 / 橡胶

轴承类型: 精密双滚珠轴承 / 滚针轴承



Double Brake

可选择双刹支架

YI-CAS-TER

Wheel Material	Model Number						
PP 塑料	I010A150PPSB	150x42	19x60	190	35x100		200
	I010A200PPSB	200x42	19x60	240	35x100		250
PVC + PP Core 塑芯 聚氯乙烯	I010A150PVCSB	150x50	19x60	190	35x100		200
	I010A200PVCSB	200x50	19x60	240	35x100		250
PU+ Cast Iron Core 铁芯聚氨酯	I010A150CPUSB	150x50	19x60	190	35x100		200
	I010A200CPUSB	200x50	19x60	240	35x100		250
Rubber + Cast Iron Core 铁芯橡胶	I010A150CRSB	150x50	19x60	190	35x100		200
	I010A200CRSB	200x50	19x60	240	35x100		250

Scaffolding Caster Type B B 款脚手架脚轮

I010

Housing:

Double brake fitting housing, zinc plated,

Wheel:

Material: Rubber+ Steel core

Bearing Type: Roller Bearing

支架:

镀锌双刹支架

轮子:

材料: 铁芯黑色橡胶

轴承类型: 滚针轴承



YI-GAS-STER

Model Number									
I010B160CRB	160x40	20x55	195	48	54	60x120/140		120	
I010B200CRB	200x46	20x55	235	48	54	60x120/140		160	

Scaffolding Caster Type C C款脚手架脚轮

I010



Y1-CAS-STER



Wheel material	Model Number						
PU + Nylon Core 尼龙芯聚氨酯	I010C125PULTB	125x40	158	Tr33.7Tr38x300/400/500	30		600
	I010C150PULTB	150x45	181	Tr33.7Tr38x300/400/500	30		700
	I010C200PULTB	200x50	241	Tr33.7Tr38x300/400/500	40		700
PA 尼龙	I010C125PALTB	125x40	158	Tr33.7Tr38x300/400/500	30		300
	I010C150PALTB	150x45	181	Tr33.7Tr38x300/400/500	30		400
	I010C200PALTB	200x50	241	Tr33.7Tr38x300/400/500	40		500
PA 尼龙	I010C125PA1LTB	125x40	158	Tr33.7Tr38x300/400/500	30		600
	I010C150PA1LTB	150x45	181	Tr33.7Tr38x300/400/500	30		700
	I010C200PA1LTB	200x50	241	Tr33.7Tr38x300/400/500	40		700
	I010C200PA2LTB	200x50	241	Tr33.7Tr38x300/400/500	40		1000

















Scaffolding Caster Type D D 款脚手架脚轮

I010



Y-L-GAS-STER



Wheel material	Model Number						
							
PU + Nylon Core 尼龙芯聚氨酯	I010D125PULSB	125x40	158	ø44x600	30		600
	I010D150PULSB	150x45	181	ø44x600	30		700
	I010D200PULSB	200x50	241	ø44x600	40		700
PA 尼龙	I010D125PALS	125x40	158	ø44x600	30		300
	I010D150PALS	150x45	181	ø44x600	30		400
	I010D200PALS	200x50	241	ø44x600	40		500
PA 尼龙	I010D125PA1LS	125x40	158	ø44x600	30		600
	I010D150PA1LS	150x45	181	ø44x600	30		700
	I010D200PA1LS	200x50	241	ø44x600	40		700
	I010D200PA2LS	200x50	241	ø44x600	40		1000

Scaffolding Caster Type E E 款脚手架脚轮

I010



Housing:

Made of pressed steel, zinc plated, double ballrace swivel head

Wheel:

Material: PU/Nylon

Bearing type: Plain bearing/Roller bearing

支架:

冲压镀锌铁支架, 双玻盘

轮子:

材料: 聚氨酯 / 尼龙

轴承类型: 滑动轴承 / 滚针轴承

Y1-CAS-STER



Wheel material	Model Number									
PU + Nylon Core 尼龙芯聚氨酯	I010E125PUPB	125x40	174	135x110	105x80	13.5x11	30		600	
	I010E150PUPB	150x45	186.5	135x110	105x80	13.5x11	30		700	
	I010E200PUPB	200x50	241	140x110	105x80	∅12	40		700	
PA 尼龙	I010E125PAPB	125x40	174	135x110	105x80	13.5x11	30		300	
	I010E150PAPB	150x45	186.5	135x110	105x80	13.5x11	30		400	
	I010E200PAPB	200x50	241	140x110	105x80	∅12	40		500	
PA 尼龙	I010E125PA1PB	125x40	174	135x110	105x80	13.5x11	30		600	
	I010E150PA1PB	150x45	186.5	135x110	105x80	13.5x11	30		700	
	I010E200PA1PB	200x50	241	140x110	105x80	∅12	30		700	
	I010E200PA1PB	200x50	241	140x110	105x80	∅12	40		1000	

Scaffolding Caster Type F F 款脚手架脚轮

I010

Housing:

Made of pressed steel, zinc plated, double ballrace swivel head

Wheel:

Material: PU/Nylon

Bearing type: Plain bearing/Roller bearing

支架:

冲压镀锌铁支架, 双玻盘

轮子:

材料: 聚氨酯 / 尼龙

轴承类型: 滑动轴承 / 滚针轴承



YI-GAS-STER



Wheel material	Model Number							
PU + Nylon Core 尼龙芯聚氨酯	I010F125PUSB	125x40	158	ø34.5x55.5/58 ø38.35x55.5/58	30		600	
	I010F150PUSB	150x45	181	ø34.5x55.5/58 ø38.35x55.5/58	30		700	
	I010F200PUSB	200x50	241	ø34.5x55.5/58 ø38.35x55.5/58	40		700	
PA 尼龙	I010F125PASB	125x40	158	ø34.5x55.5/58 ø38.35x55.5/58	30		300	
	I010F150PASB	150x45	181	ø34.5x55.5/58 ø38.35x55.5/58	30		400	
	I010F200PASB	200x50	241	ø34.5x55.5/58 ø38.35x55.5/58	40		500	
PA 尼龙	I010F125PA1SB	125x40	158	ø34.5x55.5/58 ø38.35x55.5/58	30		600	
	I010F150PA1SB	150x45	181	ø34.5x55.5/58 ø38.35x55.5/58	30		700	
	I010F200PA1SB	200x50	241	ø34.5x55.5/58 ø38.35x55.5/58	30		700	
	I010F200PA1SB	200x50	241	ø34.5x55.5/58 ø38.35x55.5/58	40		1000	

Shock Absorbing Caster Type A / B A/B 款减震脚轮

I011



Features:

1. Double ball bearing
2. PU + Cast iron core wheel
3. Single/double Springs
4. High load capacity
5. Zinc plated bracket

特性:

1. 双滚珠轴承
2. 配铁芯聚氨酯轮子
3. 单 / 双弹簧
4. 高载重
5. 镀锌支架



I011AXXXCPUP-2

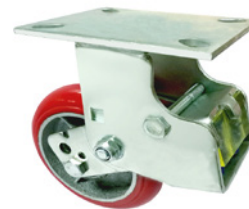

I011AXXXCPUPF-2



I011AXXXCPUPB5-2

Double Springs Type



Model Number								
I011A125CPUP-2	125x50	210	140x108	105x75	13x22		280	
I011A150CPUP-2	150x50	222	140x108	105x75	13x22		300	
I011A200CPUP-2	200x50	265	140x108	105x75	13x22		350	

Optional color :
可选择蓝色支架:



I011BXXXCPUP-1



I011BXXXCPUPF-1



I011BXXXCPUPB5-1

Single Spring Type



Model Number								
I011B125CPUP-1	125x50	190	158x113	125x75	13x25		280	
I011B150CPUP-1	150x50	200	158x113	125x75	13x25		300	
I011B200CPUP-1	200x50	245	158x113	125x75	13x25		350	

Y1-CAS-STER

Shock Absorbing Caster Type C C 款减震脚轮

I011



Features:

1. Ball bearing
2. TPR wheel
3. Double spring
4. Chrome plated bracket

特性:

1. 滚珠轴承
2. 配热塑性橡胶轮子
3. 双弹簧
4. 镀铬支架



I011CXXXTPRP



I011CXXXTPRPF



I011CXXXTPRPB6



Model Number							
I011C075TPRP	75x32	113.5	95x70	73.5x48.5	22x13		70
I011C100TPRP	100x32	138	95x70	73.5x48.5	22x13		100
I011C125TPRP	125x32	163.5	95x70	73.5x48.5	22x13		120

Y1-CAS-STER

Floor Lock 顶高器

I012



Applicable to transport mobile equipments, should be used together with casters of the same height.

适用于运输移动设备，应配合相同高度脚轮使用。



Model Number							
Style							kg
I012-J4	143	151	125	120x120	95x95	22x11	300
I012-J5	164	172	146	120x120	95x95	22x11	300
I012-J6	190	198	158	120x120	95x95	22x11	300
I012-J8	240	248	208	120x120	95x95	22x11	300
I012-A4	141	149	125	115x100	85x72	20x11	300
I012-A5	161	169	141	115x100	85x72	20x11	300
I012-A6	189	197	169	115x100	85x72	20x11	300
I012-A8	239	247	219	115x100	85x72	20x11	300

YI-CAS-STER

Shopping Cart Caster 购物车脚轮

I013

Application:
Shopping carts

Material:
TPR/PU

应用：
购物车

材料：
热塑性橡胶 / 聚氨酯



Model Number						
I013A100PUT-2	100x30	135	/	12x15		80
I013A125PUT-2	125x32	155	/	12x15		100
I013A100PUT-3	100x22	135	/	12x15		70
I013A125PUT-3	125x22	155	/	12x15		90
I013A125PUT-4	125x32	155	/	12x15		110
I013B100PUT	100x32	130	/	1/2-13x4/5		60
I013B125PUT	125x32	150	/	1/2-13x4/5		80
I013C075TPRD	75x26	98	12.5	/		60
I013C100TPRD	100x32	129	12.5	/		80
I013C125TPRD	125x32	155	12.5	/		100



YI-GAS-STER

Waste Bin Caster 垃圾桶脚轮

I014



weibida

Housing:

Made of pressed steel, zinc plated, double ballrace swivel head

Wheel:

Material: Rubber+ Steel core/PP core

Bearing type: Roller bearing/Plain bearing

支架:

冲压铁支架, 镀锌, 双玻盘

轮子:

材料: 铁芯橡胶 / 塑芯橡胶

轴承类型: 滚针轴承 / 滑动轴承

Comply with European EN8XX standard

符合欧洲 EN8XX 标准



Wheel material	Model Number							kg
Rubber+ Steel core 铁芯橡胶	I014A150CRP	150x50	195	135x110	105x80	18x11		130
	I014A200CRP	200x50	245	135x110	105x80	18x11		150
Rubber+ PP core 塑芯橡胶	I014A150PRP	150x50	195	135x110	105x80	18x11		130
	I014A200PRP	200x50	245	135x110	105x80	18x11		150

Y1-CAS-STER

Stair Climbing Wheel 爬梯轮

I015

Housing:

Zinc plated steel

Wheel:

Material: Rubber+ Steel core

Bearing type: Roller bearing

支架:

镀锌铁支架

轮子:

材料: 弹力橡胶 + 铁芯

轴承类型: 滚针轴承



Model Number									
I015A160	160x40	20x55	367	207	25	180			130



I016

Leveling Caster 水平调节脚轮

Housing:

Made of pressed steel, zinc plated

Wheel:

Material: PVC/Nylon

Bearing type:

Precision double ball bearing

支架:

冲压铁支架, 镀锌

轮子:

材料: 聚氯乙烯 / 尼龙

轴承类型: 精密双滚珠轴承



Wheel material	Model Number							
PVC + PP Core 塑芯 聚氯乙烯	I016A040PVCP	40X20	60	66x66	44x44	8		40
	I016A050PVCP	50X24	74	66x66	44x44	8		50
	I016A063PVCP	63x32	93	93x62	74x45	8		65
	I016A075PVCP	75x32	105	93x62	74x45	8		80
	I016A100PVCP	100x32	130	93x62	74x45	8		100
PA 尼龙	I016B063PAP	63X50	91	120x120	95x95	9		300
	I016B075PAP	75X50	100	120x120	95x95	9		350

YI-GAS-STER

Leveling Caster 水平调节脚轮

I016



YI-CAS-TER

Model Number								Single wheel 	Four wheels
I016-040F/S	40x20	75+8	55x55x3	42x42	6.5	M8x10	50	100	
I016-060F/S	50x25	85+10	73x73x5	58x58	7	M12x18	250	500	
I016-080F/S	62x31	110+12	90x90x5	70x70	9	M12x18	500	1000	
I016-100F/S	75x32	120+12	95x95x5	70x70	11	M16x24	750	1500	
I016-120F/S	75x32	120+12	95x95x6	70x70	11	M16x24	1000	2000	
I016-150F/S	90x55	132±15	100x100x6	70x70	13	/	1500	3000	

Other color options :

其它颜色选择:



Blue
蓝色



Golden
金色



Green
绿色



Dark blue
宝蓝色



Black
黑色



Ivory white
象牙白

Optional Fixed Stem

可选择固定螺杆

I016-XXS



Workbench Caster 工作台脚轮

I017

The workbench caster can help you easily move and position your heavy workbench, stand and open-base saws to where you want to put them to. To use workbench casters, please push down the foot pedals to elevate your workbench off the floor, move to the expected location, then lift up the foot pedal to lower the workbench and make it firmly back onto the floor.

Sturdy steel construction and high-quality wheels ensure the ruggedness and durability of the casters and make the casters so stable that they won't sway. All parts are easy and convenient to assemble.



I017065WB

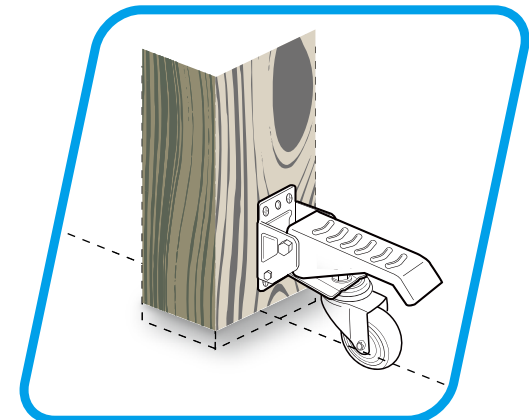
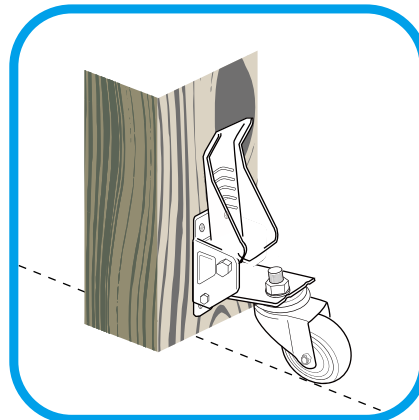

YLCASSTER

Hand Pallet Wheel 叉车轮

I018



Features:

- 1. Double ball bearing
- 2. PU+cast iron core

Applications:

Hand Pallets

特性:

- 1. 双滚珠轴承
- 2. 聚氨酯 + 铁芯

应用:

叉车



Model Number					
I018B80050CPU	80x50	20x50			450
I018B80060CPU	80x60	20x60			500
I018B80070CPU	80x70	20x70			600
I018B80080CPU	80x80	20x80			700
I018B80090CPU	80x90	20x90			800
I018B80100CPU	80x100	20x100			850
I018F160CPU	160x50	20x50			350
I018F180CPU	180x50	20x50			700
I018F200CPU	200x50	20x50			1000

YI-GAS-TER

Hand Pallet Wheel 叉车轮

I018

Features:

- 1. Double ball bearing
- 2. Nylon/Polymer

Applications:

Hand Pallets

特性:

- 1. 双滚珠轴承
- 2. 尼龙 / 共聚

应用:

叉车

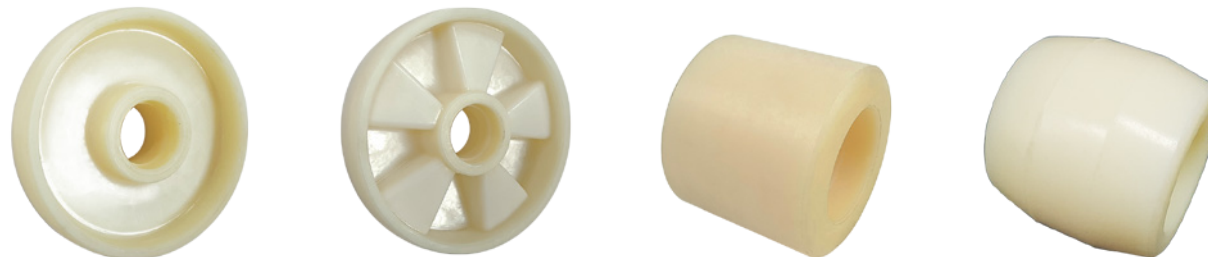

Model Number				
I018B80060PA/FP	80x60	20x60		500/450
I018B80070PA/FP	80x70	20x70		600/550
I018B80080PA/FP	80x80	20x80		700/650
I018B80090PA/FP	80x90	20x90		800/750
I018B80100PA/FP	80x100	20x100		850/800
I018F160PA	160x50	20x50		350
I018F180PA/FP	180x50	20x50		650/600
I018F200PA/FP	200x50	20x50		1000/950

YI-GAS-STER

Groove Caster 槽轮

I019



Features:
Double ball bearing,
yellow zinc-plated

特性:
双滚珠轴承,
镀彩锌

H Groove Caster
H 槽轮



U Groove Caster
U 槽轮



V Groove Caster
V 槽轮



Model Number								
I019A032HP	32x25	40	56x31	42x18	6		100	
I019A050HP	50x30	60	68x39	54x23	6		150	
I019A060HP	60x30	72	90x41	76x27	6		250	
I019A080HP	80x31	90	100x43	86x28	6		300	
I019A100HP	100x32	115	110x46	95x29	8		500	
I019A120HP	120x40	135	120x56	99x40	8		600	
I019A032UP	32x25	40	56x31	42x18	6		100	
I019A050UP	50x30	60	68x39	54x23	6		150	
I019A060UP	60x30	72	90x41	76x27	6		250	
I019A080UP	80x31	90	100x43	86x28	6		300	
I019A100UP	100x32	115	110x46	95x29	8		500	
I019A120UP	120x40	135	120x56	99x40	8		600	
I019A032VP	32x25	40	56x31	42x18	6		100	
I019A050VP	50x30	60	68x39	54x23	6		150	
I019A060VP	60x30	72	90x41	76x27	6		250	
I019A080VP	80x31	90	100x43	86x28	6		300	
I019A100VP	100x32	115	110x46	95x29	8		500	
I019A120VP	120x40	135	120x56	99x40	8		600	

Groove Caster 槽轮

I019

Features:
Single ball bearing,
yellow zinc-plated

特性:
单滚珠轴承,
镀彩锌

V Rail Caster
V型导轨轮



U Rail Caster
U型导轨轮



V Lower pulley
V型下滑轮



Model Number								
I019B050VP	50x15	59	85x28	55	9		100	
I019B060VP	60x17	64	85x28	55	9		150	
I019B070VP	70x20	80	100x35	76	9		200	
I018B080VP	80x20	85	100x35	76	9		250	
I019B090VP	90x20	100	110x36	92	9		275	
I019B100VP	100x20	105	130x36	92	9		300	
I019B050UP	50x15	59	85x28	55	9		100	
I019B060UP	60x17	64	85x28	55	9		150	
I019B070UP	70x20	80	100x35	76	9		200	
I018B080UP	80x20	85	100x35	76	9		250	
I019B090UP	90x20	100	110x36	92	9		275	
I019B100UP	100x20	105	130x36	92	9		300	
I019C050V	50x15	50	106x27	85	9		100	
I019C060V	60x17	66	106x27	85	9		150	
I019C070V	70x20	70	130x33	105	9		200	
I019C080V	80x20	80	130x33	105	9		250	
I019C090V	90x20	90	152x33	127	9		275	
I019C100V	100x20	100	152x33	127	9		300	



YI-GAS-STER

Heat Resistant Caster 耐高温脚轮

I020



Housing:
Steel welded construction, zinc plated, double ballrace swivel head
Wheel:
Material: Glassfibre+Nylon/Phenolic
Bearing type: Double ball bearing /Plain bearing

支架:
焊接镀锌铁支架, 双玻璃盘
轮子:
材料: 玻纤 + 尼龙 / 酚醛
轴承类型: 双滚珠轴承 / 滑动轴承

Remark: Continuous high temperature resistance not more than 4 hours

备注: 连续耐高温使用不可超过 4 小时



I020MXXXPF2P I020MXXXPF2PF I020MXXXPF2PB

YI-CAS-STER



Wheel Material	Model Number											
Phenolic 酚醛 -20~180°C	I020M075PFP	75x32	105	93x62	72x45	93x62	72x45	12x8.5	12x30		80	
	I020M100PFP	100x32	130	93x62	72x45	93x62	72x45	12x8.5	12x30		90	
	I020M125PFP	125x32	155	93x62	72x45	93x62	72x45	12x8.5	12x30		100	
GF + PA 玻纤 + 尼龙 -20~280°C	I020M075PF2P	75x35	105	93x62	72x45	93x62	72x45	12x8.5	12x30		80	
	I020M100PF2P	100x35	130	93x62	72x45	93x62	72x45	12x8.5	12x30		90	
	I020M125PF2P	125x35	155	93x62	72x45	93x62	72x45	12x8.5	12x30		100	

Heat Resistant Caster 耐高温脚轮

I020



Y1-CAS-STER

Housing:

Steel welded construction, zinc plated, double ballrace swivel head

Wheel:

Material: Glassfibre+Nylon/Phenolic
Bearing type: Roller bearing

Remark: Continuous high temperature resistance not more than 4 hours

支架:

焊接镀锌铁支架, 双玻盘

轮子:

材料: 玻纤 + 尼龙 / 酚醛
轴承类型: 滚针轴承

备注: 连续耐高温使用 不可超过 4 小时



I020HXXXPPF



I020HXXXPPF



I020HXXXPPFB1



Wheel Material	Model Number								
Phenolic 酚醛 -20~160°C / -20~260°C	I020H100PFSW	I020H100PPF	100x50	142	115x100	85x72	20x13		300
	I020H125PFSW	I020H125PPF	125x50	167	115x100	85x72	20x13		350
	I020H150PFSW	I020H150PPF	150x50	195	115x100	85x72	20x13		400
	I020H200PFSW	I020H200PPF	200x50	240	115x100	85x72	20x13		500
GF + PA 玻纤 + 尼龙 -20~280°C	I020H100PF1SW	I020H100PF1P	100x50	142	115x100	85x72	20x13		300
	I020H125PF1SW	I020H125PF1P	125x50	167	115x100	85x72	20x13		350
	I020H150PF1SW	I020H150PF1P	150x50	195	115x100	85x72	20x13		400
	I020H200PF1SW	I020H200PF1P	200x50	240	115x100	85x72	20x13		500

Conductive Caster 导电脚轮

I021



Housing:

Steel welded construction, zinc plated, double ballrace swivel head

Wheel:

Material: Thermoplastic rubber (With conductive filament)
 Bearing type: Double ball bearing/Annular bearing
 Conductivity : $1 \times 10^{3-5} \Omega$

支架:

焊接镀锌铁支架, 双玻盘

轮子:

材料: 塑芯热塑性橡胶 (加导电丝)
 轴承类型: 双滚珠轴承 / 一体轴承
 导电系数: $1 \times 10^{3-5} \Omega$



I021MXXXCTPRP



I021MXXXCTPRPF



I021MXXXCTPRPB

Wheel Material	Model Number										
TPR + PP Core 塑芯 热塑性橡胶	I021M075CTPRP	75x32	105	93x62	72x45	93x62	72x45	12x8.5	12x30		80
	I021M100CTPRP	100x32	130	93x62	72x45	93x62	72x45	12x8.5	12x30		90
	I021M125CTPRP	125x32	155	93x62	72x45	93x62	72x45	12x8.5	12x30		100

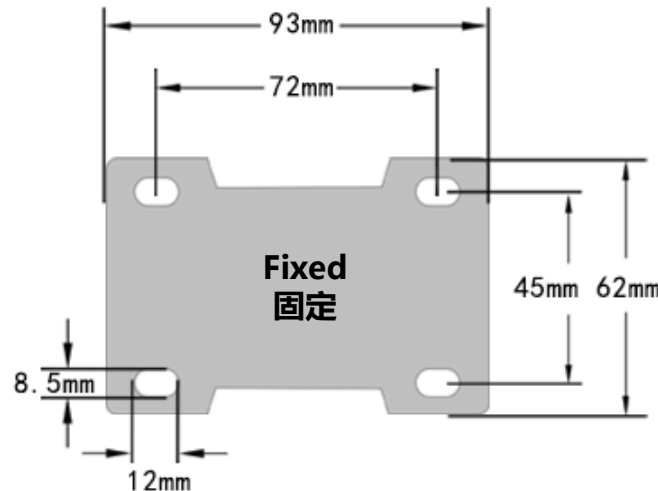
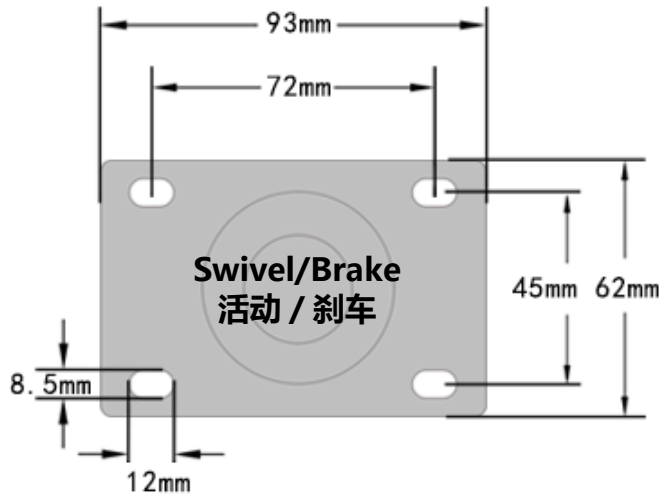

YI-CAS-STER

Conductive Caster 导电脚轮

I021

Housing:

Steel welded construction, zinc plated, double ballrace swivel head

Wheel:

Material: Thermoplastic rubber (With conductive filament)
Bearing type: Double ball bearing/Roller bearing
Conductivity : $1 \times 10^3 - 5 \Omega$

支架:

焊接镀锌铁支架, 双球盘

轮子:

材料: 塑芯热塑性橡胶 (加导电丝)
轴承类型: 双滚珠轴承 / 滚针轴承
导电系数: $1 \times 10^3 - 5 \Omega$



Wheel Material	Model Number								
TPR + PP Core 塑芯热塑橡胶	I021H100CTPRP	I021H100CTPRPF	I021H100CTPRPB	101x50	143	115x100	85x72	20x13	230
	I021H125CTPRP	I021H125CTPRPF	I021H125CTPRPB	126x50	165	115x100	85x72	20x13	280
	I021H150CTPRP	I021H150CTPRPF	I021H150CTPRPB	152x50	191	115x100	85x72	20x13	300
	I021H200CTPRP	I021H200CTPRPF	I021H200CTPRPB	202x50	241	115x100	85x72	20x13	320



I021HXXXCTPRP



I021HXXXCTPRPF



I021HXXXCTPRPB

YI-GAS-STER

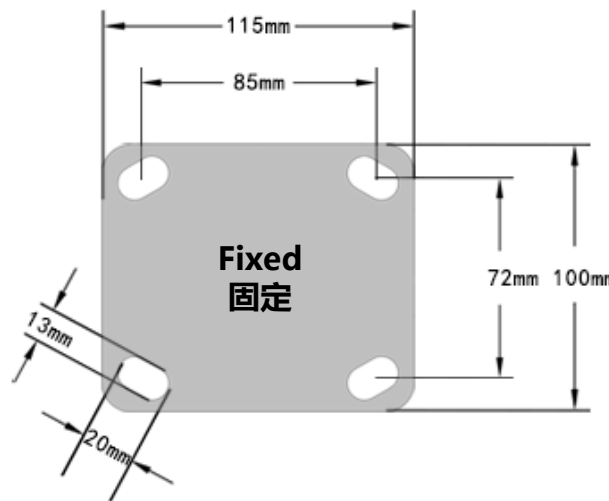
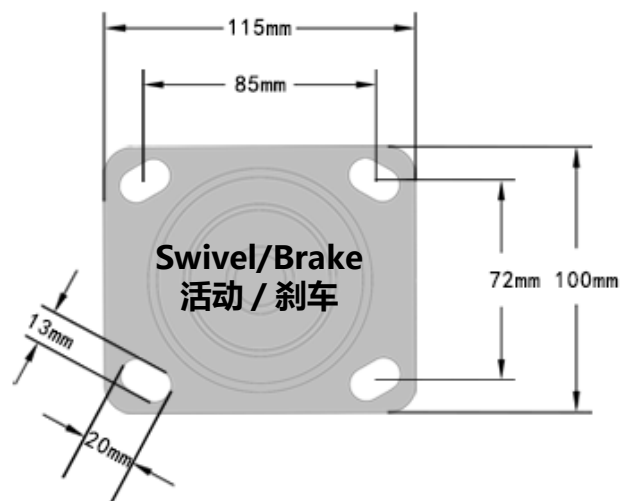

Anti-Static Caster 防静电脚轮

I022



Housing:

Steel welded construction, zinc plated, double ballrace swivel head

Wheel:

Material: Thermoplastic rubber

Bearing type: Double ball bearing/Annular bearing

Conductivity: $1 \times 10^6 - 9 \Omega$

支架:

焊接镀锌铁支架, 双球盘

轮子:

材料: 热塑性橡胶

轴承类型: 双滚珠轴承 / 一体轴承

导电系数: $1 \times 10^6 - 9 \Omega$



I022MXXXATPRP



I022MXXXATPRPF



I022MXXXATPRPB

Wheel Material	Model Number										
TPR + PP Core 塑芯 热塑橡胶	I022M075ATPRP	75x32	105	93x62	72x45	93x62	72x45	12x8.5	12x30		80
	I022M100ATPRP	100x32	130	93x62	72x45	93x62	72x45	12x8.5	12x30		90
	I022M125ATPRP	125x32	155	93x62	72x45	93x62	72x45	12x8.5	12x30		100

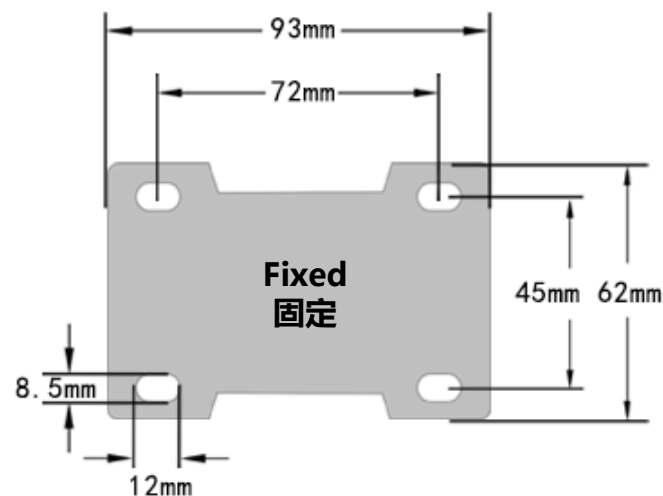
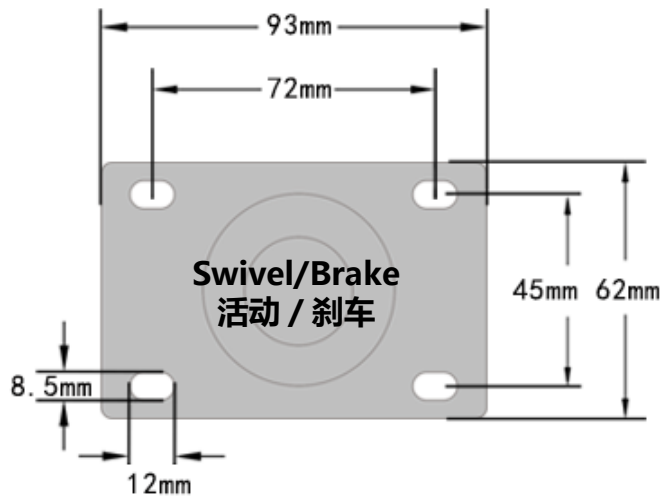

YI-CASSTER

Anti-Static Caster 防静电脚轮

I022

Housing:

Steel welded construction, zinc plated, double ballrace swivel head

Wheel:

Material: Thermoplastic rubber
Bearing type: Double ball bearing/Roller bearing
Conductivity : $1 \times 10^6 - 9 \Omega$

支架:

焊接镀锌铁支架, 双玻盘

轮子:

材料: 热塑性橡胶
轴承类型: 双滚珠轴承 / 滚针轴承
导电系数: $1 \times 10^6 - 9 \Omega$



Wheel Material	Model Number								
TPR + PP Core 塑芯 热塑橡胶	I022H100ATPRP	I022H100ATPRPF	I022H100ATPRPB	101x50	143	115x100	85x72	20x13	230
	I022H125ATPRP	I022H125ATPRPF	I022H125ATPRPB	126x50	165	115x100	85x72	20x13	280
	I022H150ATPRP	I022H150ATPRPF	I022H150ATPRPB	152x50	191	115x100	85x72	20x13	300
	I022H200ATPRP	I022H200ATPRPF	I022H200ATPRPB	202x50	241	115x100	85x72	20x13	320



I022HXXXATPRP



I022HXXXATPRPF



I022HXXXATPRPB

Y1-CAS-STER

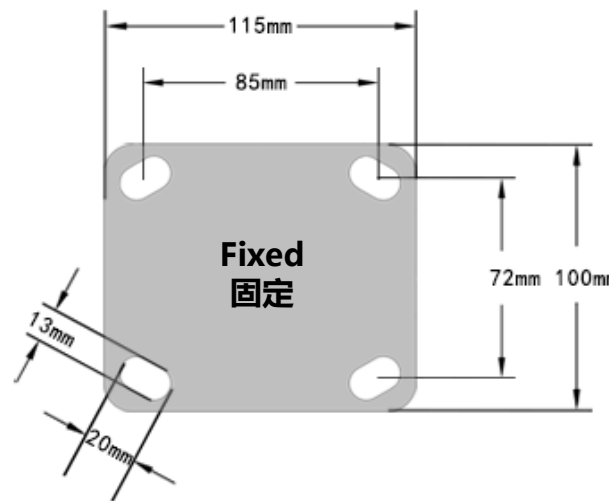
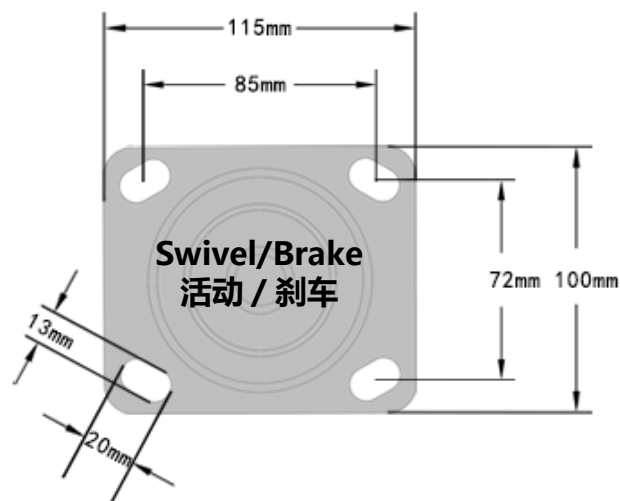

Food Cart Caster 餐车脚轮

I023



Housing:

Made of pressed steel, zinc plated,
double ballrace swivel head

Wheel:

Material: Thermoplastic rubber
Bearing type: Plain bearing

支架:

冲压镀锌铁支架,
双玻璃盘

轮子:

材料: 热塑性橡胶
轴承类型: 滑动轴承



I023AXXTPRG



I023AXXTPRGB



I023AXXTPRSG



I023AXXTPRSGB



Model Number											
I023A100TPRG	I023A100TPRGB	I023A100TPRSG	I023A100TPRSGB	100x27	125	15x42	23x68		70		
I023A100TPR1G	I023A100TPR1GB	I023A100TPR1SG	I023A100TPR1SGB	100x27	125	15x42	23x68	/	70		

YI-CASSTER

Food Cart Caster 餐车脚轮

I023

Housing:
Made of pressed steel, zinc plated,
Wheel:
Material: PP
Bearing type: No bearing

支架:
冲压铁支架, 镀锌
轮子:
材料: 塑料
轴承类型: 无轴承



Model Number					
I023C060PPT	60x17.5	85	8x15	/	20



Housing:
Made of pressed steel,
electrophoresis finished
Wheel:
Material: PP
Bearing type: No bearing

支架:
冲压铁支架, 电泳
轮子:
材料: 塑料
轴承类型: 无轴承



Model Number					
I023D075PPG	75x11	89	6x25	/	20

Housing:
Welded steel bracket,
electrophoresis finished
Wheel:
Material: Cast iron
Bearing type: No bearing

支架:
焊接铁支架, 电泳
轮子:
材料: 铸铁
轴承类型: 无轴承



Model Number					
I023E088CT	88x16.3	110	M10x15	/	60

YI-GAS-THER

Plastic Caster 塑料轮

F001

Application:

Office chairs, small cabinets, baby beds, trolleys

Material:

PP/Nylon

应用:

办公椅子, 小柜子, 婴儿床, 手推车

材料: 塑料 / 尼龙



F001AXXPAP



F001AXXPAPB6



F001AXXPAT



F001AXXPATB6



F001AXXPAG



F001AXXPAGB6



F001AXXPAS



F001AXXPASB6



F001AXXPASL



F001AXXPASLB6



F001AXXPAPAU



F001AXXPAPB6AU

Model Number															
F001A030PAP	30	41	38	/	/	/	30x30	19x19	5	8x12	/	/	/	/	8
F001A040PAP	40	55	48	48	48	48	38x38	23x23	5	8x12	11x22	7x15	8x36	19x34	18
F001A050PAP	50	62	57	57	57	57	38x38	23x23	5	8x12	11x22	7x15	8x36	19x34	25



YI-GAS-TER

Ball Caster 球轮

F002

Application:

Small trolleys, furniture

Material:

PP/Rubber

应用:

小推车, 家具

材料: 塑料 / 橡胶



YI-GAS-STER



F002A040PPP



F002A050PPP



F002A040PPT



F002A050PPG



F002A050PPSL

Model Number													
F002A040PPP	40	50	56	56	56	38x38	26x26	5	8x15	11x22	8x38	20	
F002A050PPP	50	60	65	65	65	38x38	26x26	5	10x15	11x22	8x38	25	

Optional bracket color :
可选支架颜色 :



Optional color of wheel :

White, Black, Red, Yellow, Green etc

可选轮子颜色 :

白色, 黑色, 红色, 黄色, 绿色等

Office Chair Caster-1 班椅轮 -1

F003



Application:

Office chairs, small cabinets, baby beds

Material: PU/Nylon

应用:

办公椅, 小橱柜, 婴儿床

材料: 聚氨酯 / 尼龙



F003AXXPUP



F003AXXPUPB6



F003AXXPUP



F003AXXPUPB6



F003AXXPUG



F003AXXPUGB6

Model Number										
F003A050PUP	50	62	57	57	38x38	26x26	5	10x15	11x22	35
F003A060PUP	60	68	68	70	38x38	26x26	5	10x15	11x22	40

Optional color :
可选颜色



YI-GAS-TER

Office Chair Caster-2 班椅轮 -2

F004

Application:

Hotel trolleys, chairs, baby beds

Material: PU/Nylon

应用：

酒店推车，大班椅，婴儿床

材料：聚氨酯 / 尼龙



F004A050XXP



F004A050XXT



F004A050XXG



Model Number												
F004A050PUP	50	68	63	63	42x42	28x28	5	34	10x15	11x22	35	
F004A050PAP	50	68	63	63	42x42	28x28	5	34	10x15	11x22	35	

YI-GAS-STER

Brown TPR Caster 棕色 TPR 脚轮

F005



Housing:

Made of pressed steel, chrome plated,
double ballrace swivel head

Wheel:

Material: Thermoplastic Rubber
Bearing type: Precision ball bearing

支架:

冲压镀铬铁支架, 双玻盘

轮子:

材料: 热塑性橡胶
轴承类型: 精密滚珠轴承



F005AXXXTPRP



F005AXXXTPRPF



F005AXXXTPRPB2



F005AXXXTPRD



F005AXXXTPRDB2



F005AXXXTPRT



F005AXXXTPRTB2

YI-GAS-TER

Model Number										
F005A025TPRP	25x12	37	38x30	29x21	4	/	6x15		10	
F005A032TPRP	32x12	44	39x33	30x24	4	/	6x15		15	
F005A038TPRP	38x16	52	46x39	36x28	5	6.5	6x15		20	
F005A050TPRP	50x20	77	60x49	45x32	6	10.5	10x25		35	
F005A063TPRP	63x20	90	70x52	52x33	6	12.5	12x30		45	
F005A075TPRP	75x25	104	73x60	54x39	8	12.5	12x30		55	

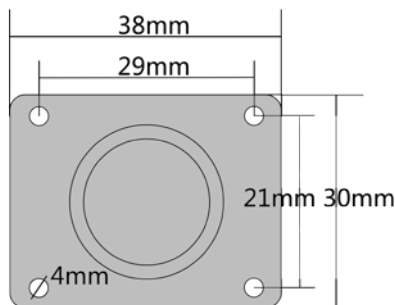

25MM Swivel/Fixed/Double Brake caster share the same plate size.
25MM 的活动 / 固定 / 双刹脚轮底板尺寸一致。

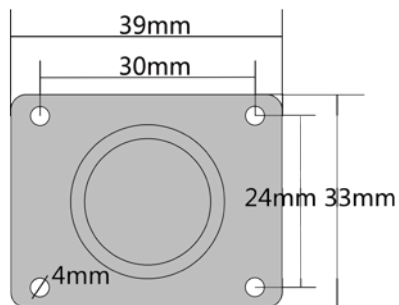

32MM Swivel/Fixed/Double Brake caster share the same plate size.
32MM 的活动 / 固定 / 双刹脚轮底板尺寸一致。

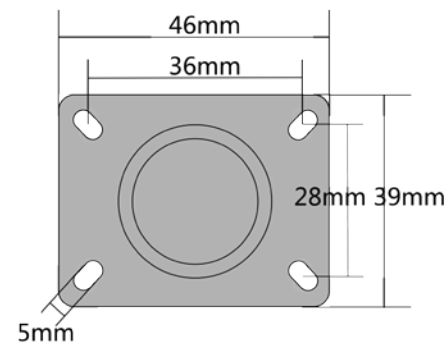

38MM Swivel/Fixed/Double Brake caster share the same plate size.
38MM 的活动 / 固定 / 双刹脚轮底板尺寸一致。

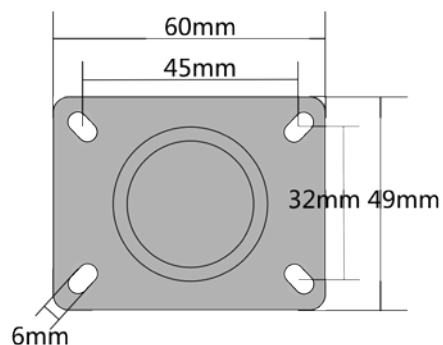

50MM Swivel/Fixed/Double Brake caster share the same plate size.
50MM 的活动 / 固定 / 双刹脚轮底板尺寸一致。

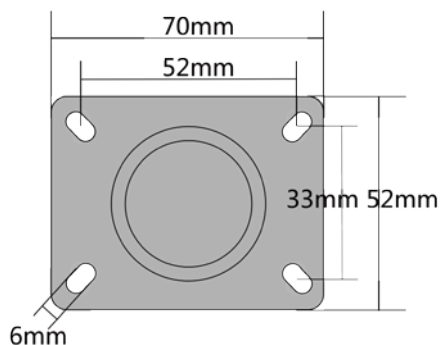

63MM Swivel/Fixed/Double Brake caster share the same plate size.
63MM 的活动 / 固定 / 双刹脚轮底板尺寸一致。

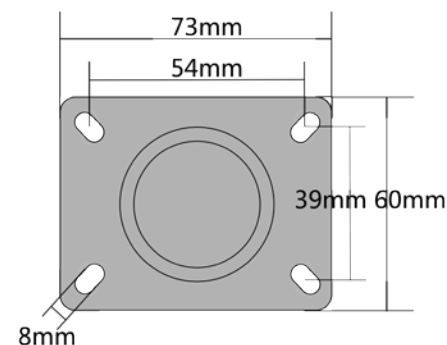

75MM Swivel/Fixed/Double Brake caster share the same plate size.
75MM 的活动 / 固定 / 双刹脚轮底板尺寸一致。

Brown TPR Caster Twin-wheel 棕色TPR双轮脚轮

F005



Housing:

Made of pressed steel, chrome plated, double ballrace swivel head

Wheel:

Material: Thermoplastic Rubber

Bearing type: Precision ball bearing

支架:

冲压镀铬铁支架, 双玻盘

轮子:

材料: 热塑性橡胶

轴承类型: 精密滚珠轴承



F005AXXXTPRP-TW



F005AXXXTPRPF-TW



F005AXXXTPRPB2-TW



F005AXXXTPRG-TW



F005AXXXTPRDG2-TW



F005AXXXTPRT-TW



F005AXXXTPRTB2-TW

Model Number												
F005A040TPRP-TW	38x16	63	72x51	52x35	70x56	52x35	11x8	8x20	11x22		60	
F005A050TPRP-TW	50x18	75	72x51	52x35	70x56	52x35	11x8	12x30	11x22		80	

YI-GAS-STER

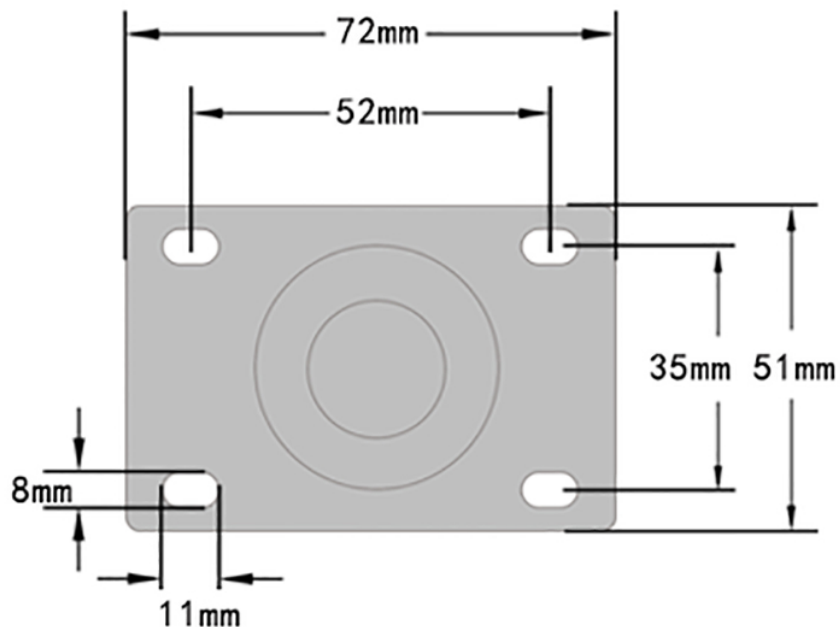

40/50MM Swivel/Double Brake caster share the same plate size.

40/50MM 的活动 / 双刹脚轮底板尺寸一致。

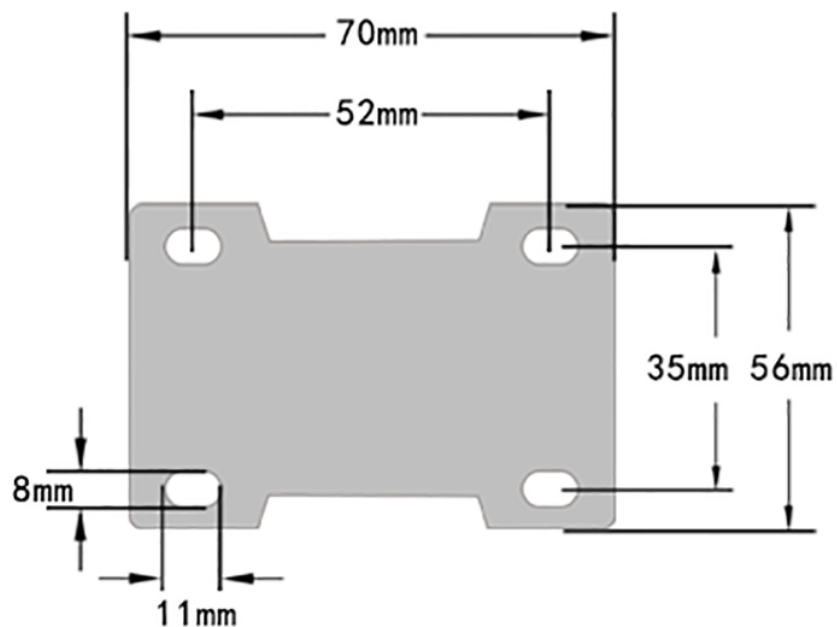

40/50MM Fixed caster share the same plate size.

40/50MM 固定脚轮底板尺寸一致。

Transparent Caster 透明脚轮

F006



Application:

Small equipments, cabinets, chairs, furniture

Material:

PU

Advantage:

Environmental protection material, no noise

应用:

小设备, 柜子, 桌椅, 家具

材料:

聚氨酯

优势:

环保材料、静音



F006AXXPUP



F006AXXPUPB6

Model Number										
F006A035PUP	F006A035PUPB6	35x24	50	42x42	31x31	4	8x15		15	
F006A050PUP	F006A050PUPB6	50x21	62	42x42	31x31	4	8x15		30	
F006A075PUP	F006A075PUPB6	75x24	97	60x60	44x44	6	10x25		50	

YI-GAS-TER

Half Transparent Caster

花芯透明脚轮

F007



Application:

Small equipments, cabinets, chairs, furniture

Material:

PU

Advantage:

Environmental protection material, no noise

应用：

小设备， 柜子， 桌椅， 家具

材料：

聚氨酯

优势：

环保材料、 静音



F007AXXPUG



F007AXXPUGB6

Model Number						
F007A050PUG	F007A050PUGB6	50x21	66	11x22		25
F007A064PUG	F007A064PUGB6	64x24	84	11x22		35
F007A075PUG	F007A075PUGB6	75x24	95	11x22		50
F007A100PUG	F007A100PUGB6	100x24	125	11x22		60

YI-GASSTER

Medical Caster-1 医疗脚轮 -1

M001



Application:

Hospital beds, medical equipment trolleys

Material:

PU/TPR

Advantage:

Environmental protection material, no noise, durable bracket

应用：

病床、医用设备推车

材料：

聚氨酯 / 热塑性橡胶

优势：

环保材料、静音效果、耐用支架



M001A075PUP



M001A100PUPB



M001A100PUT



M001A125PUTB

Model Number								
M001A075PUP	75x56	102	76x61	60x45	8.5	12x25	/	60
M001A100PUP	100x56	125	90x75	70x55	8.5	12x25		80
M001A125PUP	125x65	155	90x75	70x55	8.5	12x25		125

Y-1-CAS-TER

Medical Caster-2 医疗脚轮 -2

M002



Application:

Hospital beds, medical equipment trolleys

Material:

TPR

Advantage:

Environmental protection material, no noise, durable bracket

应用：

病床、医用设备推车

材料：

热塑性橡胶

优势：

环保材料、静音效果、耐用支架



M002AXXXTPRP



M002AXXXTPRPB2



M002AXXXTPRT



M002AXXXTPRTB2

Model Number										
M002A075TPRP			75x56	103/98	70x58	55x43	8.5	12x25	/	75
M002A100TPRP			100x56	130/123	80x65	55x43	8.5	12x25		95
M002A125TPRP			125x65	160/155	95x68	73x45	8.5	12x25		110

YI-GAS-TER

M003



Application:

Hospital beds, medical equipment trolleys

Material:

TPR

Advantage:

Environmental protection material, no noise, durable bracket

应用：

病床、医用设备推车

材料：

热塑性橡胶

优势：

环保材料、静音效果、耐用支架

Model Number									
M003A075TPRP	75x24	102	76x61	60x45	8.5	12x25	/		60
M003A100TPRP	100x30	125	90x75	70x55	8.5	12x25	/		80
M003A125TPRP	125x32	155	90x75	70x55	8.5	16x30	28x40		125



Optional wheels :
匹配脚轮：



Y1-CAS-STER



YI-GAS-STER



M003AXXTPRP



M003AXXTPRPB2



M003AXXTPRT



M003AXXTPRTB2



M003AXXTPRS



M003AXXTPRSB2

Medical Caster-4 医疗脚轮 -4

M004



Application:

Hospital beds, medical equipment trolleys

Material:

TPR

Advantage:

Environmental protection material, no noise, durable bracket

应用:

病床、医用设备推车

材料:

热塑性橡胶

优势:

环保材料、静音效果、耐用支架

YI-CAS-TER

Model Number										
M004A075TPRP	76x32	120	96x63	75x45.5	12x8.4	13.1	12x25	28x40		90
M004A100TPRP	101x32	149	96x63	75x45.5	12x8.4	13.1	12x25	28x40		120
M004A125TPRP	126x32	177.5	96x63	75x45.5	12x8.4	13.1	16x30	28x40		135

Optional wheel type:
匹配脚轮款式:





YILGASSTER



M004AXXXTPRP



M004AXXXTPRPB2



M004AXXXTPRD



M004AXXXTPRDB2



M004AXXXTPRT



M004AXXXTPRTB2



M004AXXXTPRS



M004AXXXTPRSB2

M005



Application:

Hospital beds, medical equipment trolleys

Material:

PU

Advantage:

Environmental protection material, no noise, durable bracket

应用：

病床、医用设备推车

材料：

聚氨酯

优势：

环保材料、静音效果、耐用支架

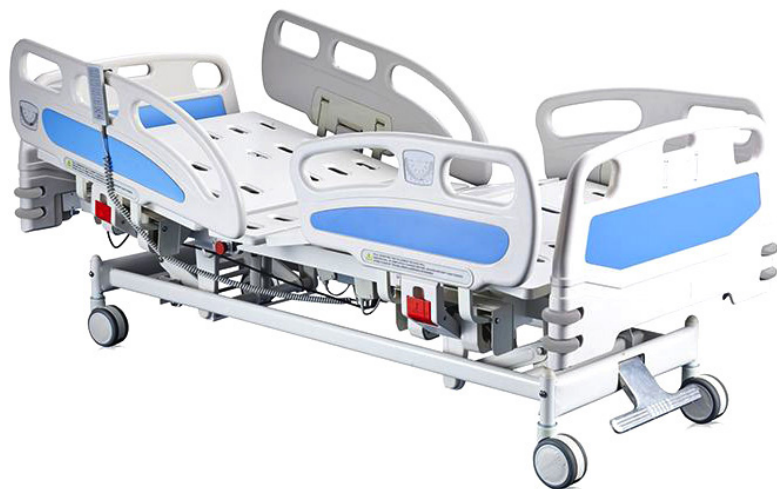

Central Locking Caster
中控脚轮

Y-L-CAS-STER

Model Number						
M005A130CS	130x66	160	32x50		120	
M005A130CL	130x66	160	28x98.5		120	

Medical Caster-6 医疗脚轮 -6

M006



YI-GAS-STER

Application:

Hospital beds, medical equipment trolleys

Material:

TPR

Advantage:

Environmental protection material, no noise, durable bracket

应用：

病床、医用设备推车

材料：

热塑性橡胶

优势：

环保材料、静音效果、耐用支架



M006AXXTPRP



M006AXXTPRS



M006AXXTPRT



M006AXXTPRPB2



M006AXXTPRSB2



M006AXXTPRTB2

Optional brake pedal

可选刹车踏板:



Model Number									
M006A075TPRP	75x32	122	95x67	73x44.5	8.5x10.5	28x45	M12x25		70
M006A100TPRP	100x32	150	95x67	73x44.5	8.5x10.5	28x45	M12x25		100
M006A125TPRP	125x32	175	95x67	73x44.5	8.5x10.5	28x45	M12x25		120

T001



Foldable Plastic Platform Trolley

- Integral construction
- Plastic(PP) platform
- TPR wheel



Model Number						
T00107050PP1	700x480	150	820	100	10.5	100

Advanced Foldable Plastic Platform Trolley

- High intensity and tenacity platform
- Plastic(Polymer) platform
- Durable TPR wheel



Model Number						
T00107050FP	700x500	150	820	100	10.5	150
T00109060FP	900x600	200	860	125	14	300

Foldable Plastic Platform Trolley

- Plastic(PP) platform
- TPR wheel

Color available: Green, yellow or customized



Model Number						
T00107050PP	700x500	150	820	100	10.5	200
T00109060PP	900x600	200	860	125	14	400
T00110563PP	1050x630	200	860	125	17	500

Foldable Hand Trolley

- Completely foldable
- Plastic(Nylon) platform
- Adjustable handle
- Space-saving



Model Number					
T001065041FC	653x415x920	653x415x85	100	7.6	150

YILGASSTER

Hand Trolley 手推车

T001



Foldable Stainless Steel Platform Trolley

- Anti-corrosion
- Waterproof and rust-proof surface
- Stainless steel platform
- TPR wheel



Model Number						
T00107050SS	700x460	150	850	100	10.5	150
T00109060SS	900x600	200	900	125	19.5	300
T00112066SS	1200x660	200	900	125	26.5	500

Foldable Square Tube Trolley

- Smooth and durable
- Steel tube
- TPR wheel



Model Number						
T00107050ST	700x460	150	850	100	10.5	150
T00109060ST	900x600	200	900	125	19.5	300
T00112066ST	1200x660	200	900	125	26.5	500

Optional wheel type:

匹配脚轮款式：



Black PVC caster
黑色 PVC 脚轮

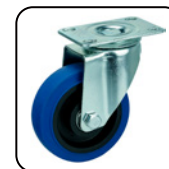

Blue TPR caster
蓝色 TPR 脚轮



Black TPR caster
全塑 TPR 脚轮

YI-GAS-STER

T002/3



Double-layers Plastic Platform Trolley

- Plastic(PP) platform
- Anti-slip handle
- TPR wheel



Model Number						
T00207050PP-2	700x500	150	820	100	17.5	150
T00209060PP-2	900x600	200	860	125	23	300

Three-layers Plastic Platform Trolley

- Plastic(PP) platform
- Anti-slip handle
- TPR wheel



Model Number						
T00207050PP-3	700x500	150	852	100	21.5	150
T00209060PP-3	900x600	200	892	125	27	300

Wire Mesh Trolley

- Plastic(PP) platform
- Removable mesh sides



Model Number						
T00309060MC	900x600	200	860	125	24	300

YI-GASSTER

Hand Trolley 手推车

T004/5

Foldable Transport Truck

- Space saving
- Completely foldable
- Anti-rusted
- PU wheel



Model Number						
T004100040BC	1000x394x406	640x394x47	390x280	100	3.5	70

Foldable Stair-Climbing Trolley

- Labor saving when climbing stairs
- Space saving
- Completely foldable
- Anti-rusted
- TPR wheel



Model Number							
T005100040BCS	405x520x1000	625x110x730	100	265	4.9	70	30

YI-GASTIER

GUANGZHOU YLCASTER METAL CO.,LTD.



Tel: +86-20-89621491

Fax: +86-20-89621430

E-mail: sale2@ylcaster.com

Web: www.ylcaster.com www.yl-caster.com

www.ylcaster.en.alibaba.com www.ylcaster02.en.alibaba.com

Office add: No.183, Tingyuan Road, Xinggang East Road, Haizhu District, Guangzhou, Guangdong, China

Factory add: B13-8 Yinling Industrial Park, Jiangcheng District, Yangjiang, Guangdong, China

Manufacturing master of caster